

# UBCO Dealer Warranty Manual

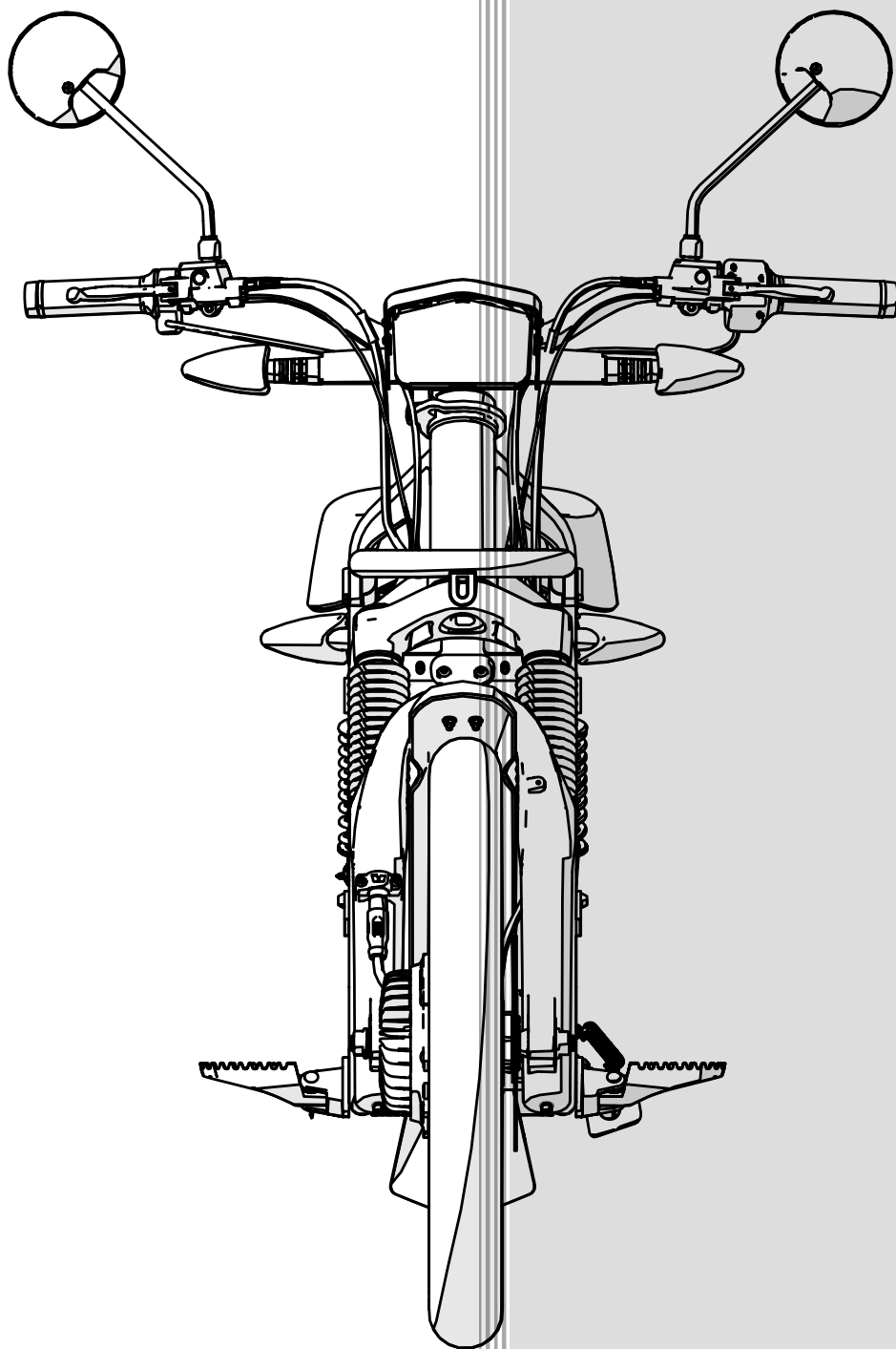

---

## Table of Contents

---

<b>WARRANTY &amp; LEGAL</b> .....	2
<b>LIMITED WARRANTY</b> .....	2
<b>STANDARD WARRANTY PERIODS</b> .....	2
<b>WARRANTY ACTIVATION PROCESS</b> .....	3
<b>WARRANTY START DATE</b> .....	3
<b>WARRANTY TRANSFERABILITY</b> .....	3
<b>UBCO RIGHT TO MAKE CHANGES</b> .....	3
<b>COMMISSIONING BY DEALER</b> .....	4
<b>COMMISSIONING BY PURCHASER</b> .....	4
<b>PRODUCTS NOT REQUIRING A PDI</b> .....	4
<b>FREIGHT QUERIES</b> .....	4
<b>MISSING OR INCORRECT PARTS</b> .....	4
<b>ADDITIONAL INFORMATION</b> .....	5
<b>GENERAL EXCLUSIONS</b> .....	5
<b>SPECIFIC CATEGORY EXCLUSIONS</b> .....	6
<b>UBCO AUTHORIZED DEALERS AND CERTIFIED TECHNICIANS</b> .....	6
<b>DEALER CLAIM SELF-APPROVAL</b> .....	6
<b>UBCO CLAIM PRE-APPROVAL</b> .....	7
<b>PARTS RETENTION POLICY</b> .....	7
<b>OWNERS OBLIGATIONS</b> .....	7
<b>RESOLVING WARRANTY CONCERNS</b> .....	8
<b>CONSUMER LAW</b> .....	8
<b>MAXIMUM LIABILITY</b> .....	8
<b>UBCO CONTACT DETAILS</b> .....	9
<b>APPENDIX 1 WARRANTY CLAIM PROCESS</b> .....	10
<b>APPENDIX 2 2X2 GENX5 ALLOCATED REPAIR TIMES</b> .....	11

## WARRANTY & LEGAL

---

The following warranty statement applies to all products sold and dispatched after the 1st of February 2023. For products sold prior to this date, please contact [Support](#) or download our 2018 Warranty or 2017 Warranty documents from the [Owners Resources](#) page.

This warranty statement applies to all products sold by UBCO Limited (“UBCO”) within the following categories (collectively referred to as the Products):

1. **Utility Electric Vehicles (UEV)** – excluding power supplies.
2. **Power Supplies (KXH Power Supply)** – includes the power supply in your UEV.
3. **Accessories.**

This warranty statement should be read in conjunction with any User Manual supplied by UBCO in relation to the relevant Product. The User Manual will contain more specific and detailed information about the relevant Product, its intended operation and use, maintenance, care, parts, and limitations.

## LIMITED WARRANTY

---

Warranty is a written guarantee by the manufacturer of a product promising to repair or replace parts which have a defect in materials, or workmanship. Limited means the warranty is for a specified period of time and has certain other restrictions.

UBCO warrants to the original retail purchaser that the Products shall be free, under normal use and maintenance, from any defects in material or workmanship for the warranty periods set out below, subject to the qualifications, exclusions, conditions, and limitations set out in this warranty statement. Where warranty conditions are met, defective Products or parts will be repaired or replaced (repair or replacement is at UBCO Limited’s discretion).

At the discretion of UBCO Limited, proof of purchase documents relating to the Product may be required in order to confirm the validity of any submitted warranty claims.

## STANDARD WARRANTY PERIODS

---

1. **UBCO 2X2** – 24 months
  1. **Ex demo UBCO 2X2** – 12 months
2. **UBCO Power Supplies** – 24 months.
3. **Accessories** – 12 months.
4. **Spare Parts** – 6 months.

## WARRANTY ACTIVATION PROCESS

---

In order to activate warranty coverage for UBCO 2X2 products, the following completed forms must be submitted to UBCO at the time of retail sale or at the time of delivery for dealer demo bikes.

1. The Pre-Delivery Inspection (PDI) form is available from UBCO Dealers
2. [Online Warranty Registration form](#)

If the above information is not received by UBCO at the time of retail sale, the manufacturer's warranty coverage relating to the affected product is deemed invalid.

At the discretion of UBCO Limited, proof of purchase documents relating to the Product may be required in order to confirm the validity of any submitted warranty claims.

## WARRANTY START DATE

---

The warranty coverage begins on the date of retail sale to an end user/consumer except for ex Demo bikes where the warranty coverage begins on the date the bike was supplied for demo purposes. The date should be entered onto the registration form and submitted to UBCO.

## WARRANTY TRANSFERABILITY

---

If an UBCO bike is sold within its original warranty period, the balance of the warranty may be transferred to the new owner. The new owner must complete and return to UBCO a Warranty Transfer Form

## UBCO RIGHT TO MAKE CHANGES

---

UBCO reserves the right to make any changes in design and changes or improvements to an UBCO Product at any time without incurring any obligation with respect to any Product previously ordered, sold, or shipped.

## COMMISSIONING BY DEALER

---

If the 2X2 Bike was purchased from an authorised UBCO Dealer or via Click & Collect on the UBCO website, the Dealer must complete the following steps.

3. Remove the bike from its original packaging.
4. Complete the Pre-Delivery Inspection (PDI) and the final bike set-up following instructions provided by UBCO.
5. Test ride the bike before final hand over to the purchaser.
6. The Registration Form (page 2 Of User Manual) must be signed by the Dealer and the purchaser and must specify who assembled and set up the bike.
7. The [Online Register](#) must also be completed by either the purchaser or Dealer.

## COMMISSIONING BY PURCHASER

---

If the 2X2 Bike was purchased and shipped directly to the purchaser from UBCO, the Pre-Delivery Inspection will have already been completed by UBCO before shipment and the following steps must be taken by the purchaser.

1. Enrol in and complete the “Your 2X2 Bike Set Up” course on [UBCO University](#).
2. Remove the bike from its original packaging and complete the final set-up following the instructions provided on the poster included with the bike and/or online via UBCO University in step 1.
3. Complete the [Online Register](#) and fill in the Registration Form at the front of the User Manual.

## PRODUCTS NOT REQUIRING A PDI

---

Products that fall within the Power Supply or Accessory categories (excluding trailers) do not require a PDI but do require proof of purchase as a condition of any warranty claim.

## FREIGHT QUERIES

---

In the event a package arrives damaged and has missing or damaged parts as a result, a picture must be taken of the unopened package and UBCO informed **within 48 hours** of receiving the delivery.

## MISSING OR INCORRECT PARTS

---

In the event you have received the incorrect items or are missing some items, UBCO must be informed **within 48 hours** of receiving the delivery.

## ADDITIONAL INFORMATION

---

- UBCO's Warranty System strictly operates a "Return-To-Base" system with all return freight at the Dealer/Customer's expense.
- Labour for work carried out by a dealer directly related to a Warranty Claim will be remunerated at an agreed hourly rate and is subject to the time allocations as described in Appendix 3;
- Time allocations for warranty repairs operations are determined by UBCO and include an allowance for the appropriate diagnostic process. It is expected that all Warranty Claims will be made in line with these Time Allocations.
- Claims for additional labour outside of the specified time allocation will be considered for approval on a case-by-case basis and at UBCO Limited's sole discretion.
- UBCO Limited reserve the right to carry out an inspection of any parts or components subject to a warranty claim. If found to be serviceable or subject to damage or misuse, the associated claim may be declined.
- The manufacturer's warranty coverage is only applicable within the country/region of original supply by UBCO LTD. Bikes that are on-sold or transferred outside of the original "supply region" are no longer subject to warranty coverage.

## GENERAL EXCLUSIONS

---

This warranty does not cover:

- Products used other than in accordance with their intended use or the use instructions / parameters set out in the relevant User Manual.
- Products that have been misused, involved in an accident, neglected, or abused.
- Products used for competition including but not limited to racing or trials.
- Products used for rental purposes or any commercial application other than those for which the Product is intended, and which have been specifically approved by UBCO.
- Products that have been improperly assembled, or where repairs have been made other than by an UBCO certified technician.
- Products that have not been maintained or serviced in accordance with the instructions set out in the relevant User Manual.
- Products altered or modified in any way from the manufacturer's specifications.
- Parts requiring replacement or repair as a result of normal wear and tear.
- Pickup or delivery of Products.
- Overtime labour rates.
- Travel time or mileage.
- Natural or accidental calamities.

## SPECIFIC CATEGORY EXCLUSIONS

---

The following exclusions also apply:

### UEV Warranty Exclusions:

- The planetary gears are considered a wear and tear item and should be regularly inspected and replaced in the event of wear. Wear is related to the level and type of use. Planetary gears and elements of the motor system are designed to protect the main motor. In extreme stress, they may be damaged in order to protect the motor's integrity.
- Brake pads and brake discs
- Mirrors and foot pegs
- If motor maintenance or repair is performed by a non-UBCO Certified Technician, including if the motor is opened or modified.
- If any of the control system parameters are modified from those issued by UBCO for public release
- If water damage occurs as a result of a UEV being used outside of its intended operation and use. Damage includes but is not limited to the following component groups: the external controls, electrical system, motors, battery connections and bearings.
- If damage is caused by over-torquing, cross threading, or other damage due to attempted repair by unauthorized service personnel.

### Power Supply Exclusions:

- If the Power supply is left in a discharged state.
- If the Plug connectors (male and female) have not been cleaned and are exposed to dirt, water, and other environmental contaminants.
- If the case has been opened or tampered with.
- If there has been damage caused to the external case or structure e.g., from dropping or accidents.
- If used with non-approved or un-certified electrical equipment.
- If the Product has been submerged under water.

## UBCO AUTHORIZED DEALERS AND CERTIFIED TECHNICIANS

---

For a list of UBCO Authorized Dealers and Certified Technicians please see our website for a current [Dealer Listing](#).

## DEALER CLAIM SELF-APPROVAL

---

In order to facilitate timely repairs, and minimise down-time for our customers, Approved UBCO Dealers and Service Agents may use their knowledge of UBCO's warranty policy to self-approve warranty claims representing a total claimed value of less than \$250+ GST.



UBCO Limited reserve the right to audit self-approved warranty claims. This may include, but is not limited to, the requirement to inspect any or all parts, components and supporting documentation relating to the claim. Any self-approved claims found not to conform to UBCO warranty policy may be declined. This is at the sole discretion of UBCO Limited. Approving claims in non-conformance UBCO Warranty policy may result in removal of the facility to self-approve Warranty claims.

Refer to Appendix 1 for the Warranty Claim process flow.  
Refer to Appendix 2 to Allocated Repair Times

## UBCO CLAIM PRE-APPROVAL

---

For claims representing a total claimed value over \$250+ GST, Approval from the UBCO warranty team is required before repairs are conducted.

Refer to Appendix 1 for the Warranty Claim process flow.  
Refer to Appendix 2 to Allocated Repair Times

## PARTS RETENTION POLICY

---

Any parts or components replaced as part of a warranty claim must be retained and stored by the repairing dealer/service agent for 90 days following completion of the repairs. Dealers/Service Agents are advised to label and store the removed parts/components in a manner that allows ease of future identification in case of a return request.

During this retention period, UBCO may request any of the removed parts are returned for inspection, or further investigation. If inspected parts are found not to have a warrantable defect, UBCO reserve the right to reject or reverse the associated warranty claim.

Upon conclusion of the 90-day retention period, dealers must render the displaced parts un-usable before disposing of them responsibly.

## OWNERS OBLIGATIONS

---

Where a User Manual is supplied with a Product, the purchaser of the Product and ultimate end user must review the Manual to understand the operations, limitations, maintenance, and care instructions for the Product.

Whilst UEV and Portable Power Supplies have fewer moving parts than a combustion engine vehicle or technology they still require maintenance to ensure continued safe operation. Every Product will need scheduled maintenance and care, to ensure your warranty is maintained. This will increase the Product's lifespan and reduce lifetime maintenance.

It is the Customer's responsibility to maintain the Products in accordance with the instructions provided in the Manual. UBCO recommends you keep records and





receipts; you may be asked to prove the maintenance instructions have been followed. It is the Owners responsibility to operate the Products in a safe manner and for the use for which they were designed. If a defect in materials or workmanship occurs, it is the Owners responsibility to cease operation until repairs are made. Damage which occurs from continued operation may not be covered by this warranty. You should contact your authorized UBCO Dealer or representative immediately so repairs can be made in a timely manner.

## RESOLVING WARRANTY CONCERNS

---

Normally, your warranty concerns can be resolved by your Dealer's Service Department. If the problem is not resolved to your satisfaction, you may want to speak with either the owner or general manager of the dealership or an UBCO representative.

You may also want to contact the UBCO office in your region for assistance. The addresses and area of coverage of each region are shown below. Before contacting, please have the following information ready.

- Your name and contact details including address, phone, and email.
- Model, serial number and date of purchase.
- Detailed description of the problem.
- Details of maintenance performed.

## CONSUMER LAW

---

Our goods come with guarantees that cannot be excluded under the Consumer Rights Act 2015. You are entitled to a replacement or refund for a major failure and compensation for any other reasonably foreseeable loss or damage. You are also entitled to have the goods repaired or replaced if the goods fail to be of acceptable quality and the failure does not amount to a major failure. Please also be aware that your rights in terms of goods guarantees are limited to only those specified in the above-mentioned national legal act and nothing else is contractually implied. Where the terms of the warranty and the provisions of the Act conflict, the provisions of the Act will prevail.

## MAXIMUM LIABILITY

---

To the maximum extent permitted by law, UBCO's maximum liability in contract, tort, equity, statute, regulation or otherwise for any loss, damage, or injury directly or indirectly resulting from any defect in, or non-compliance of, or use of, the Product will not in aggregate exceed the price (excluding GST) for the Product that caused the loss, damage or injury.

UBCO Ltd, UBCO Australia Pty/Ltd , UBCO Bikes US, LLC, Utility Bike Company UK, and UBCO Europe ApS, makes no express or implied warranties including, but not limited to, any implied warranty of merchantability or fitness for a particular purpose, except as expressly set forth in the above warranty.

## UBCO CONTACT DETAILS

---



### NEW ZEALAND

20B Newton Street  
Mt Maunganui 3116

+64 (07) 543 1640  
M-F 8am-5pm

#### SALES

[Sales email](#)

#### CUSTOMER SERVICE

[Support email](#)

---



### AUSTRALIA

15/238 Governor Road  
Braeside, VIC 3195

+61 407849281  
M-F 8am-5pm (AEST)

#### SALES

[Sales email](#)

#### CUSTOMER SERVICE

[Support email](#)

---



### UNITED STATES

155 Garfield St H5  
Eugene, OR 97402

+01 (541) 357-4067  
M-F 8am-5pm PST

#### SALES

[Sales email](#)

#### CUSTOMER SERVICE

[Support email](#)

---



### UNITED KINGDOM

EEMC  
Electric House, Unit 1  
Hall Farm, Church Road  
Diss IP22 1RJ

+44 (0) 1379 898 987

#### SALES & CUSTOMER SERVICE

[Sales and Support email](#)

---



### EMEA

Bragesgade 8B  
2200 Copenhagen  
Denmark

+45 89 87 43 52

#### SALES

[Sales email](#)

#### CUSTOMER SERVICE

[Support email](#)

## APPENDIX 1 WARRANTY CLAIM PROCESS

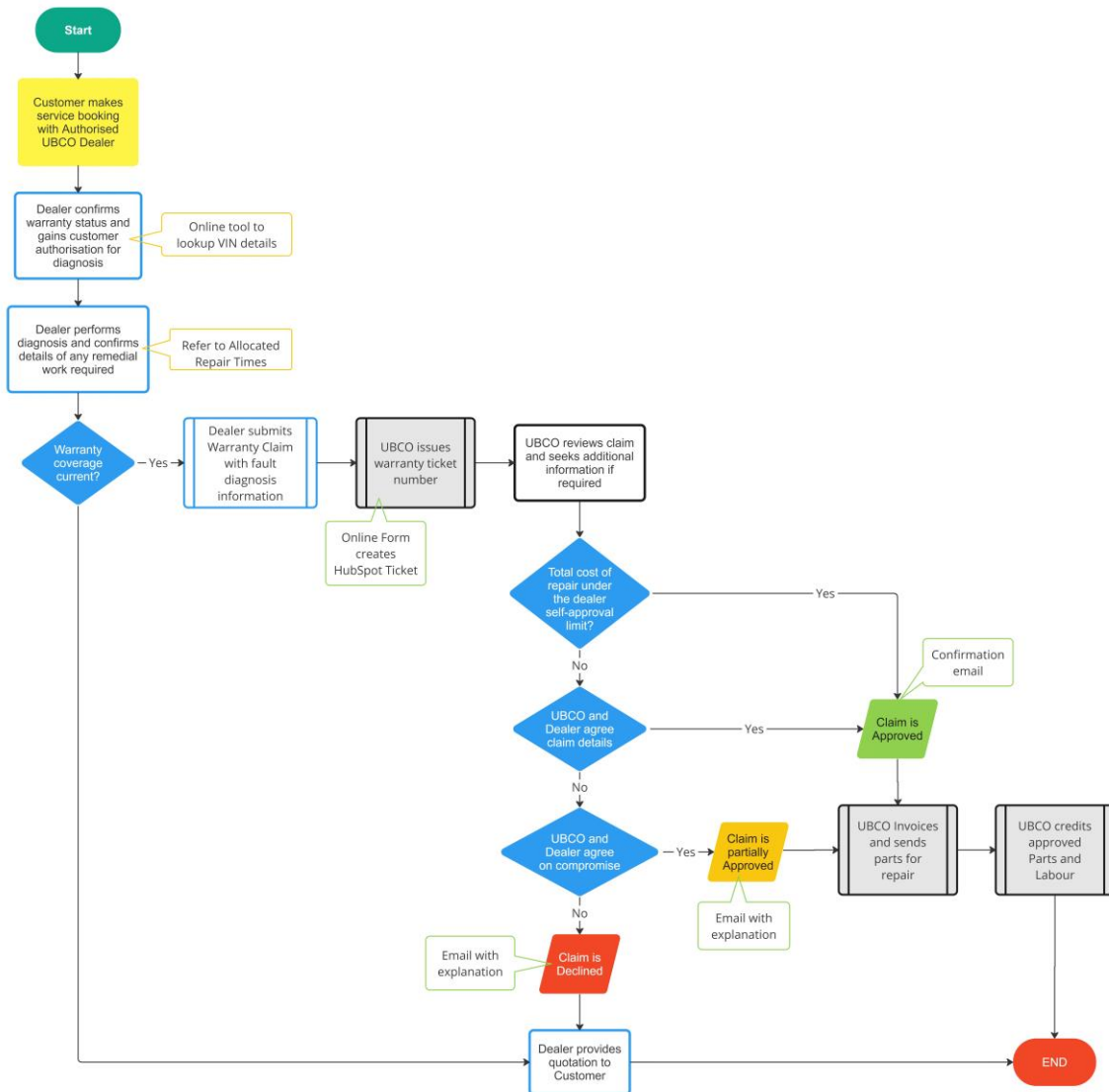

## APPENDIX 2 2X2 GENX5 ALLOCATED REPAIR TIMES

The purpose of this table is to provide an exhaustive list of all repair procedures and the specified allocated repair times. These times will assist with warranty and repair invoice approval. Repairs may exceed the allocated time due to unforeseen factors. The justification of exceeded time should accompany the invoice, approval will be at the UBCO reviewer's discretion.

SERVICE TASK	ALLOCATED TIME (1.0 = 60min)
<b>BATTERY</b>	
Battery plug replacement	0.25 (15 mins)
BMS replacement	1.0 (60 mins)
<b>BRAKE SYSTEM</b>	
Front brake unit replacement	0.5 (30 mins)
Rear brake unit replacement	0.75 (45 mins)
Brake pad set replacement per calliper	0.25 (15 mins)
Brake unit bleed	0.75 (45 mins)
<b>ELECTRICAL</b>	
Horn replacement	0.17 (10min)
Motor controller replacement	0.25 (15 mins)
VMS replacement	0.5 (30 mins)
Indicator replacement	0.08 (5min)
Taillight replacement	0.17 (10min)
Rear Motor cable replacement	0.5 (30 mins)
Front Motor cable replacement	0.25 (15 mins)
Display cable replacement	0.25 (15 mins)
<b>FRAME</b>	
Seat replacement	0.17 (10min)
Foot peg replacement	0.17 (10min)
Kickstand replacement	0.17 (10min)
Frame replacement	2.5 (150 mins)
<b>HANDLEBAR</b>	

Ethrottle replacement	0.25 (15 mins)
Digital display replacement	0.25 (15 mins)
Lever guard installation	0.25 (15 mins)
Headlight replacement	0.25 (15 mins)
Handlebar grips replacement	0.25 (15 mins)
<b>INSPECTION</b>	
Assemble 2X2 from box	0.25 (15 mins)
Pre-Delivery Inspection (PDI)	1.0 (60 mins)
<b>HUB MOTOR</b>	
Motor service	0.5 (30 mins)
Motor service + Planetary gear replacement	0.67 (40min)
Motor service + Planetary gear & Bearing replacement	0.83 (50min)
Motor Service + Hall sensor replacement	1.0 (60 mins)
Motor Service + Temperature sensor replacement	1.0 (60 mins)
Motor Service + Hall sensor + Temperature sensor	1.17 (70 mins)
Motor core & gears complete assembly replacement	0.75 (45 mins)
<b>SERVICE</b>	
10hr service	0.5 (30 mins)
Fleet Service incl replacement of both brake pad sets	0.83 (50 mins)
Intermediate service	1.0 (60 mins)
Full service (includes the service of both Hub motors)	2.0 (120 mins)
Full service + Planetary gear replacement	2.17 (130 mins)
Full Service + Planetary gear & Bearing replacement	2.33 (140 mins)
<b>SUSPENSION</b>	
Rear suspension pair replacement	0.5 (30 mins)
Swing arm replacement	0.75 (45 mins)
Front fork replacement	0.5 (30 mins)
Front fork boot replacement	0.75 (45 mins)
<b>WHEEL ASSEMBLY</b>	
Wheel replacement	0.17 (10min)
Tyre Inner tube replacement using a tyre machine	0.25 (15 mins)
Brake rotor replacement	0.5 (30 mins)

# UBCO

Tyre replacement	0.25 (15 mins)
Spoke replacement	0.5 (30 mins)
Complete spoke replacement & rebalance	2.0 (120 mins)