

PRERIDE CHECKLIST

2X2

WORK BIKE

Before you head out on your 2X2, always check that your bike is ready to ride.

1. Check your **power supply** is sufficiently charged.
2. Ensure the **battery strap and plug** are secured tightly.
3. Ensure the **lights** are working: headlight and rear lights.
4. Test the **brakes** & the **horn** are functioning properly.
5. Check the **tyre pressure**; inflate if needed.
6. Do a **physical check** to ensure all nuts, bolts, and fixings are tight and all loads are secure.
7. Always wear a helmet and appropriate clothing and footwear.

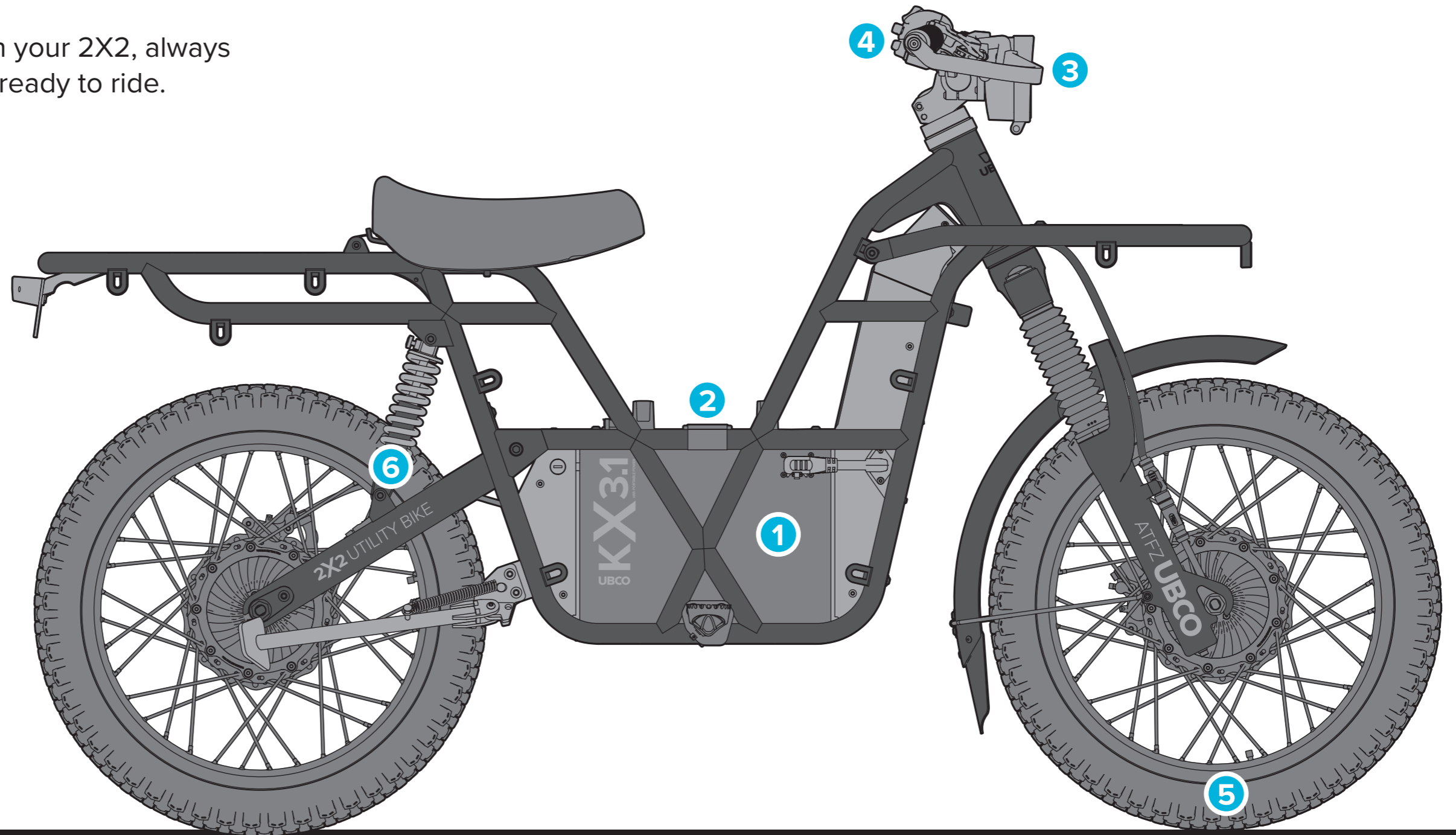

ubcobikes.com
info@ubcobikes.com
@ubcobikes #ubco2x2



UBCO 2X2 WORK BIKE

KIA ORA HELLO.

If your 2X2 has arrived in the box, here's how to set up your new ride.

Lift up the seat to find a Field Kit with all the tools you need for assembly and some basic maintenance. Scissors or a knife will also be handy and a torque wrench, if you have one.



Scan this QR code to watch our bike assembly video.

If you don't feel confident putting your bike together, contact us for help.

V3.3

GET READY

- Keep the bike standing in the base to help align the handlebars. Remove the protective packaging from the bike.
- Find the Field Kit under your seat and set out the tools you'll need.
- Note: Remember to remove the guidance stickers after each step is completed.

1. Align the handlebars

- Loosen the side bolts on the stem with a 5mm Allen key. Straighten the handlebars in line with the front wheel and so the orange dots align.
- Once the handlebars are straight, re-tighten the stem bolts, alternating as you go to prevent damage to the clamp. Align the marking on the bolt head to achieve the correct tightness. Torque to 15Nm, if available.

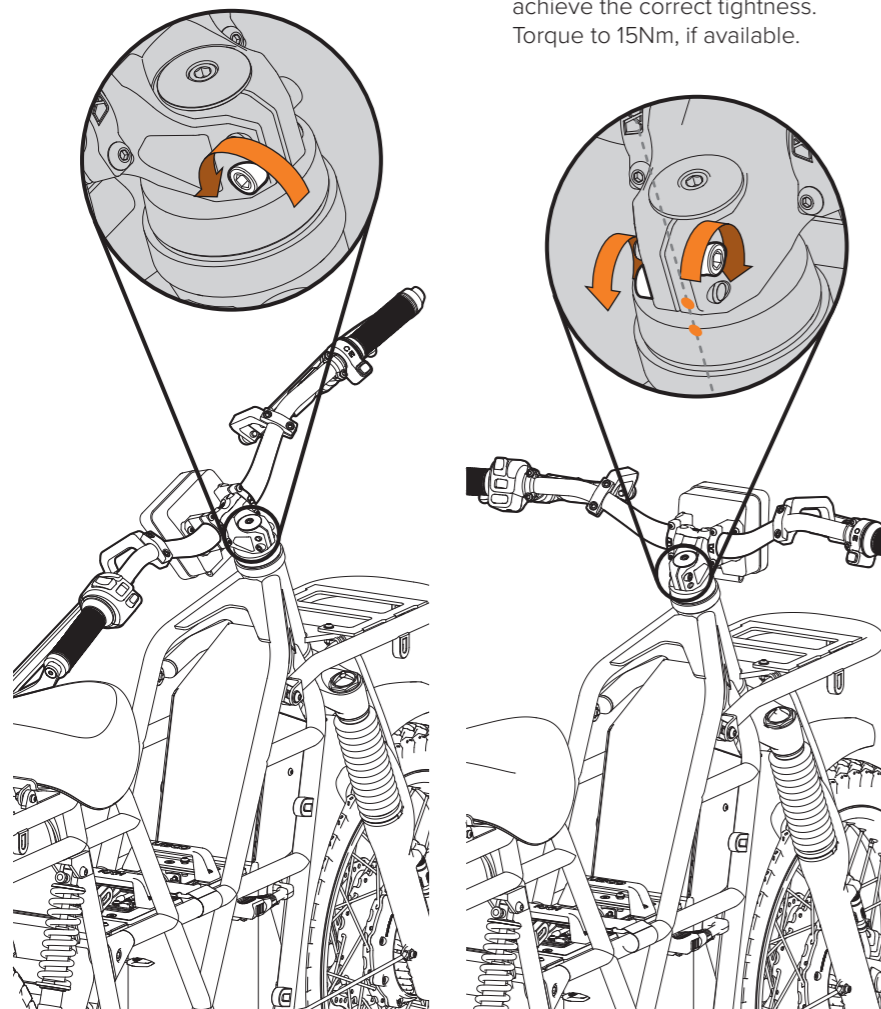

2. Fit the right-hand kickstand

- Remove the kickstand from the packaging and remove the two mounting bolts.
- Fit the kickstand on the outer side of the kickstand mount and insert bolts with the washer on the bolt head side.
- Tightly fasten the bolts using a 5mm Allen key and 13mm spanner. (Tighten to 22Nm if you have a torque wrench).

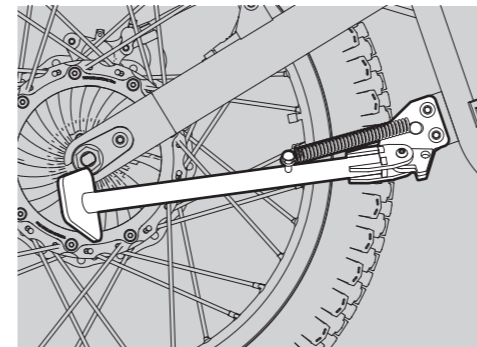

3a. Install the power supply

- IMPORTANT:** inspect the power supply; contact UBCO if there is any transit damage.
- If the power supply is not already in place, remove the battery strap from the frame and set aside. With the power socket on the right-hand side of the bike, carefully lower the power supply into place with both hands.
- Plug the bike's power plug into the power socket. Use the securing key to lock the power supply in place.
- Secure the battery strap as shown (3b).

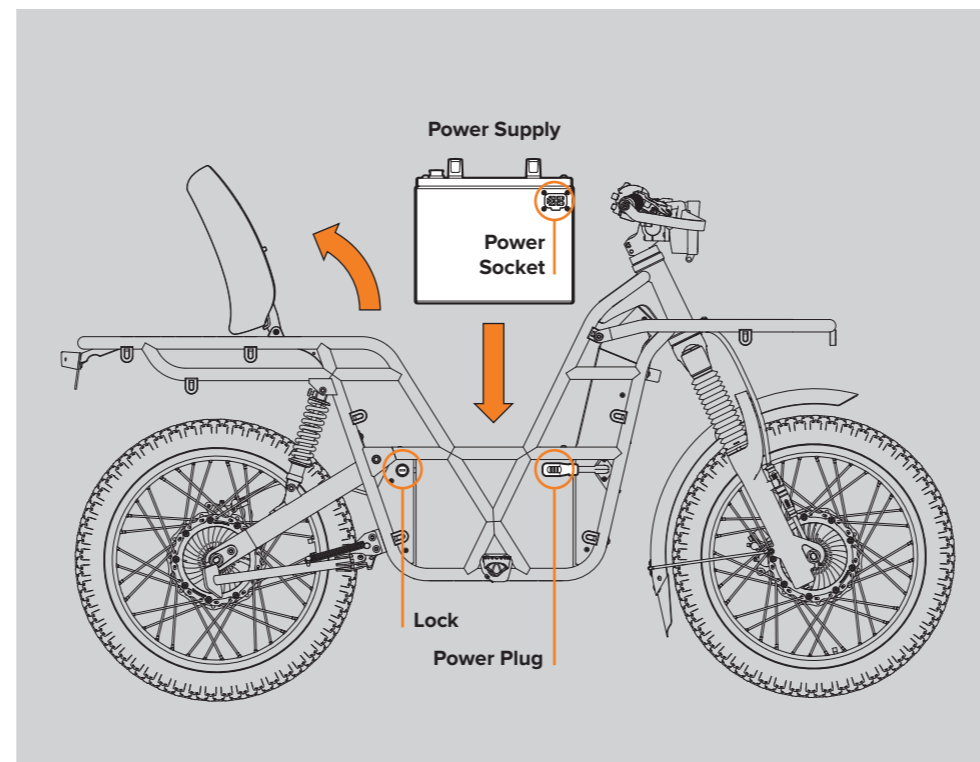

3b. Secure the battery strap

- Velcro side down, tuck the end of the battery strap under the left hand bar, central to the power supply.
- Carry the strap over the power supply and tuck it under the right hand bar. Feed the strap back through the clip and centre the clip.
- Tighten the strap and secure it closed.

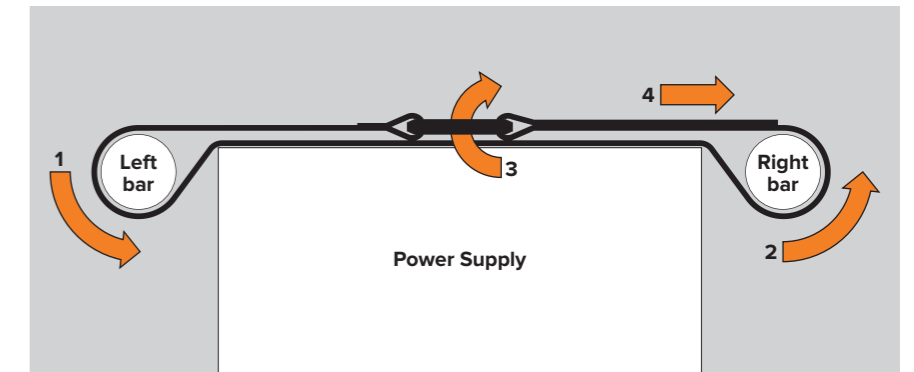

READY TO RIDE

STEP 1:

Download the UBCO App

You can download the UBCO App to view speed and battery charge, control the settings of your 2X2, and get critical updates delivered wirelessly. Simply search for UBCO in your phone's app store and download it for free. Make sure Bluetooth is activated on your mobile device when connecting the app to your 2X2.

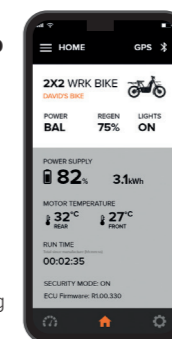

STEP 2:

Turn on the 2X2

Grab your keys and power the bike by pressing the button on the key fob 1.5 seconds until you hear a beep. You can now open the app and connect your bike. See the complete riding instructions in the User Manual on page 16.

Securing key

Key fob

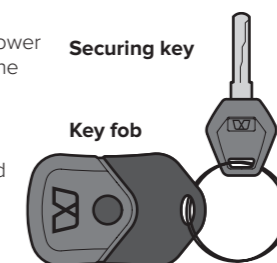

STEP 3:

Check power supply charge

View the charge level on the Home and Live Dash screens of the app. Your power supply will arrive with partial charge, enough to ride for a few minutes. Be sure to fully charge up before you plan a longer ride.

STEP 4:

Before you ride

Ensure you've read the user manual and are familiar with how to use the bike and proper safety precautions. Always wear a helmet. Once you're ready to ride, twist the throttle and GO!!!

Find UBCO online:

- ubcobikes.com
- [fb.com/ubcobikes](https://www.facebook.com/ubcobikes)
- [instagram.com/ubcobikes](https://www.instagram.com/ubcobikes)
- [youtube.com/ubcobikes](https://www.youtube.com/ubcobikes)

Join the UBCO Owners group for tips and tricks from our community.
[facebook.com/groups/ubcoowners](https://www.facebook.com/groups/ubcoowners)