

Pre-Ride Checklist

Before you head out on your 2X2, always check that your bike is ready to ride.

1. Battery

Ensure there is enough charge to carry out your work or journey. Check that the battery strap is secured tightly.

2. Brakes

Check the brakes are working and inspect their brake pads for wear.

3. Lights

Ensure the headlight, rear light, and brake light are working.

4. Kickstand

Check the kickstands are functional, especially if the bike is loaded up, and check it stays up when retracted. Retract the kickstand before riding.

5. Horn

Sound the horn to ensure it's working.

6. Tires

Check the condition and pressure of the tires.

7. Loose Fixings

Ensure all the fixings (nuts & bolts) are done up correctly and secure.

8. Load

Ensure all functional parts of the bike are not obstructed by any load you may be carrying.

9. Wear Safe

For your safety, please wear a helmet and appropriate riding gear.

10. Keys

Remember to take your key fob with you (unless you've turned security mode off).

Have Fun!



DO NOT ride the bike if it is materially defective in operation, damaged, or missing safety-related equipment. Physically check off each of the above before you ride.

How to Get Your 2X2 Assembled



Before You Start

Under your seat with the Field Kit, you'll find all the tools to assemble the bike. Feel free to contact us for help assembling the bike or scan the QR code to watch our "How to" video.

1. ALIGN THE HANDLEBARS

Loosen the side bolts on the stem with a 5mm Allen key. Straighten the handlebars in line with the front wheel and so the orange dots align.

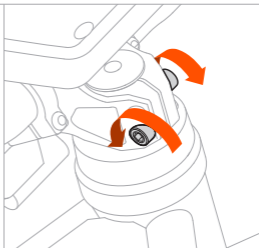

Once the handlebars are straight, re-tighten the stem bolts, alternating as you go to prevent damage to the clamp. Align the marking on the bolt head to achieve the correct tightness. Torque to 15Nm, if available.

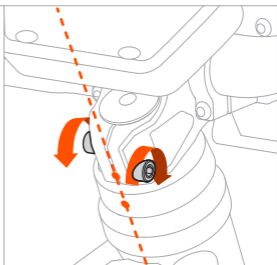
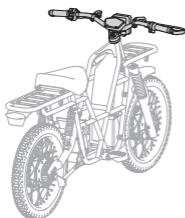

2. FIT THE KICKSTAND

Remove the kickstand from the packaging and remove the two mounting bolts.

Fit the kickstand on the outer side of the right-hand kickstand mount and insert bolts with the washer on the bolt head side.

Tightly fasten the bolts using a 5mm Allen key and 13mm spanner. (Tighten to 22Nm if you have a torque wrench).

Remove any additional packaging or protective film.

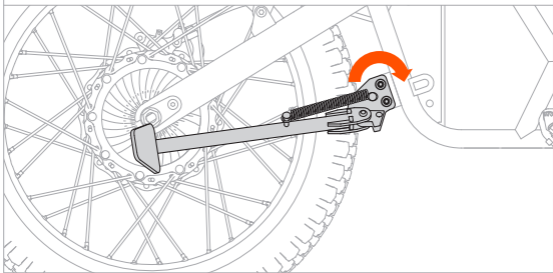

3. INSTALL THE BATTERY

IMPORTANT: inspect the battery; contact UBCO if there is any damage from transit.

If the battery is not already in place, remove the battery strap from the frame and set aside. With the power socket on the right-hand side of the bike, carefully lower it into place with both hands.

- A. Power Socket
- B. Power Plug
- C. Battery Lock

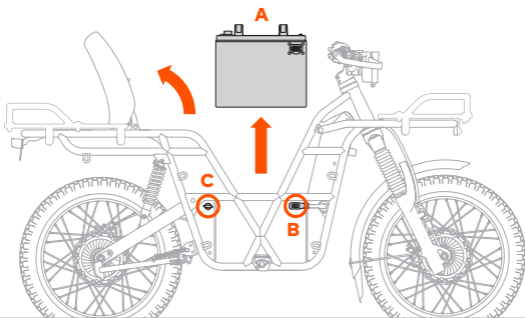

4. SECURE THE BATTERY

Plug the bike's power plug into the power socket on the righthand side of the battery.

Use the securing key to lock the battery in place.

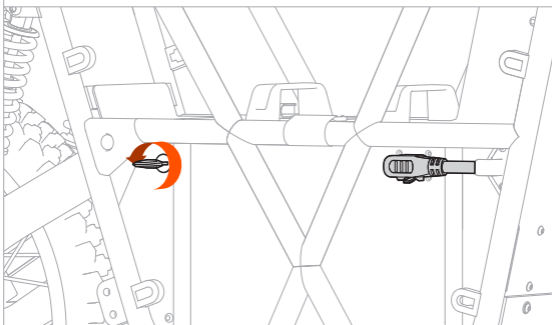

5. ATTACH THE BATTERY STRAP

Velcro side down, tuck the end of the battery strap under the left hand bar, central to the battery.

Carry the strap over the battery and tuck it under the right hand bar. Feed the strap back through the clip and center the clip. Tighten the strap and secure closed.

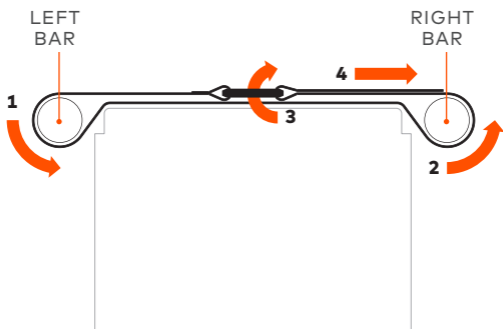

Please refer to the 'Accessories Install Guide' for instructions on installing the accessories that don't come already installed.

How to Get Your 2X2 Started

STEP 1

Turn On Bike



Hold the key fob button for 1.5 seconds to turn the bike on and into Neutral. Listen for a short beep.

Before you head out on your 2X2 , always complete the pre-ride checklist. For your safety, please wear a helmet and appropriate riding gear.

STEP 2

Hop on and retract the kickstand

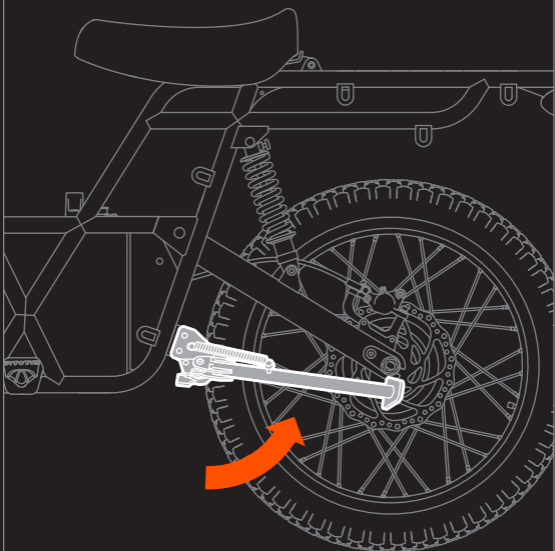

If you're ready to ride, hop on the bike and retract the kickstand. Do not drive with the kickstands out.

Download the UBCO rider's app to help you along the way:



STEP 3

Engage the bike and go!

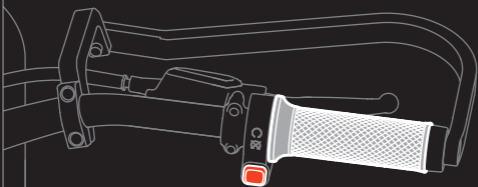

Press the red button to enable Drive. The headlight will turn on. Twist the throttle towards you to go.

2X2 Hunt Edition

USER MANUAL
MODEL: 2024

UBCO

2X2 User Manual

CONTENTS

1. YOUR KEYS
2. HANDLEBAR CONTROLS
3. LCD DISPLAY
4. SUSPENSION
5. YOUR BATTERY
6. RIDING SAFETY
7. LOADING THE 2X2
8. ALERT CODES

First things first:

Registration your information at www.ubco.com/register

This ensures we know about your purchase and is required for any future warranty claims. Keep your receipt of purchase somewhere safe, such as stapled to this manual, and record your serial number, which is engraved on the right-hand side of the frame head tube.

Next:

Download the UBCO App from any app store. Keep the app updated and it will keep your bike up to date.

Enable Bluetooth and location services on your phone and ensure your 2X2 is turned on and in range before opening the app.

Then:

Read this manual carefully. Pay special attention to the safety messages that appear throughout. This manual should be considered a permanent part of the 2X2 and should remain with your bike if it is resold.



IMPORTANT: When you see this symbol, the information following is important for safety and proper function of the 2X2. Please take care to read text with this warning.

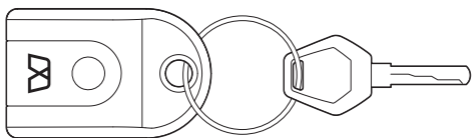

1. YOUR KEYS

The 2X2 comes with two types of keys: a key fob and a securing key. The key fob is used to turn the bike on or off, while the securing key activates the battery lock.

1.1 Powering the Bike

The key fob will turn the 2X2 on but the kill switch is used to change between Neutral and Drive.

Neutral: The bike will turn on but the throttle is inactive.

Drive: Throttle is activated and the lights turn on.

Hold the key fob button 1.5 seconds to turn the bike on in Neutral.

If you're ready to ride, straddle the bike and retract the kickstands, then press the kill switch to enable Drive. The headlight will turn on.

Twist the throttle towards you to go.

Once stopped, press the kill switch to turn the bike back to Neutral. To turn bike off from Neutral, hold the key fob button for 1 second or hold the kill switch for 2 seconds.

To turn bike off from Drive, press either the key fob button or the kill switch button for 2 seconds.



The 2X2 is very quiet due to its electric drive motors and **will not rev** when it is turned to Drive or when the throttle is turned.

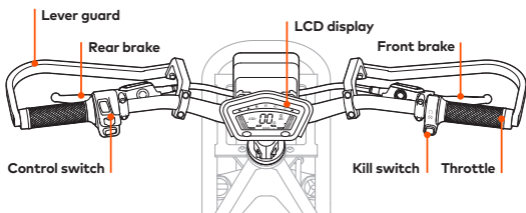

2. HANDLEBAR CONTROLS

2.1 Control Switch

On the left side of the handlebar you will find a control switch with buttons for the headlight and the horn. The indicator switch is inactive.

The headlight and tail lights automatically come on when the 2X2 is in Drive. To turn off the headlight, either switch to Neutral using the key fob, open settings in the UBCO Rider's App and turn lights off, or hold the low beam switch until it turns off (repeat to turn back on).

Holding the high beam switch will activate the headlight in Neutral for when temporary lighting is required while the throttle is inactive.

2.2 Throttle

To accelerate, twist the throttle towards you. There are no gears or clutch, so the throttle controls all acceleration from start to top speed (excluding gravity).

To maintain a constant speed, hold the throttle in a constant position. If you let go of the throttle, the 2X2 will start to decelerate.

Note: Do not continuously power the throttle when the 2X2 is held stationary.

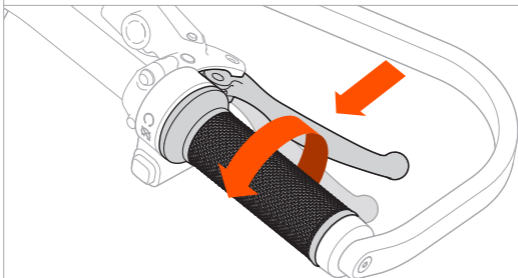

2.3 Kill Switch

On the right side of the handlebar, next to the throttle, is the kill switch for the motors. When the kill switch is activated, the bike will change to Neutral.

To ensure the 2X2 can be ridden, retract the kickstand and press the kill switch to deactivate it (Drive).

2.4 Security Mode

Security Mode determines whether the key fob is required to power the bike. Security Mode is on by default, meaning the key fob is required to turn the bike on.

To turn Security Mode OFF:

This enables the bike to be powered without the key fob; the bike is only turned on using the kill switch.

This process can only be performed using a fob that is already paired to the bike.

1. Turn off the bike.
2. Press and hold both the key fob button and the kill switch for approximately 10 seconds.
3. The bike will beep a few times while the buttons are held and then give one final long beep to indicate programming is complete.
4. The bike can now be turned on using only the kill switch.

To turn Security Mode back on, repeat the above steps.



Turning off **Security Mode** will allow anyone with access to the bike to turn it on and use it.

2.5 Brakes

To slow down, allow the throttle to return to neutral position and then apply the brakes:

left = rear, right = front.

The UBCO drive system incorporates a two-level regenerative braking system, where the motors themselves apply controlled braking prior to the mechanical brakes taking effect. The amount of regen braking is adjustable in the UBCO Rider's App.

- Level 1 is a gentle "engine braking" effect when the throttle is released.
- Level 2 kicks in when the brake levers are initially pressed, just prior to the mechanical brake pads, adding more motor braking when the brake levers are engaged fully.

This system not only saves brake pad wear, but also transfers energy back into the bike's battery, to maximise range. It's a win-win!

Tip: The brake lever angle can be adjusted using the screws on the brake lever mount. Ensure they're re-tightened to 7Nm torque setting.

3. LCD DISPLAY

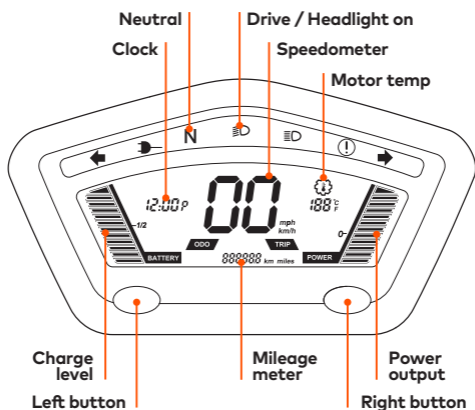

← Left indicator

→ Right indicator

☾ Charge required

⚠ Warning

☾ Lights on / Lo beam

ODO Odometer displayed

☾ Lights on / Hi beam

TRIP Trip meter displayed

3.1 Warning Light

If there is a system issue, the warning light will flash and an alert code will be displayed in the odometer area. Find more information in the UBCO App or contact your local UBCO support line.

3.2 Charge Level

Accurate state of charge (SOC) is displayed on the left side of the display, split into 12 segments. The charge level is split up into 12 segments with a halfway indicator. The charge required indicator will light up when battery SOC is getting low.

3.3 Power Output Meter

This displays the real-time power output to the motors. Any bars shown above the 0 mark represent power output to the motors and any bars shown under the 0 mark represent power input to the battery through regenerative braking.

4. ADJUSTABLE SUSPENSION

The front and rear suspensions have adjustable rebound controls that change the rate at which the suspension re-extends after an impact. They also feature spring preload adjustment that are helpful for setting the loaded ride height of the vehicle and help determine the suspension's ability to prevent bottoming out (AKA setting the Sag).

These adjustments allow the rider to set the loaded ride height for various use cases and terrains to improve the handling and capability of the vehicle.

For more demanding terrain, or higher load carrying capacity, we recommend increasing the preload to prevent harsh bottom out forces.

Please see recommendations for various riding situations on reverse side.

4.1 Front:

Rebound speed is adjusted on the right-hand side of the fork crown. Twist the dial clockwise to slow the rebound; counter-clockwise to speed it up.

On the left side of the fork, the spring preload is adjusted. Twist the dial clockwise to lessen the spring force; counter-clockwise will increase the spring force.

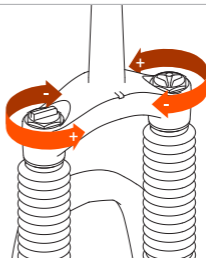
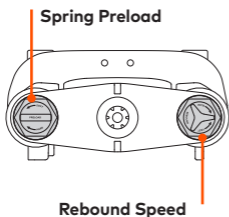

4.2 Rear:

Rebound control can be adjusted using the red dial at the top of the spring. Twist the dial counter-clockwise to slow the rebound; clockwise speeds it up (this is opposite to the front fork).

To adjust the rear spring preload, wind the disk at the base of the spring clockwise to lessen the spring force; twist counter-clockwise to increase the spring force. The rear suspension preload and rebound controls should be set equally on both sides of the bike.

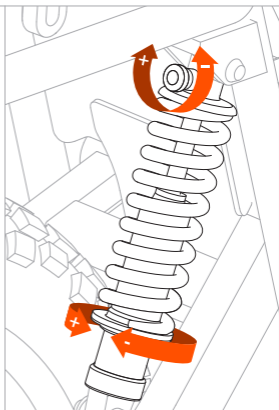
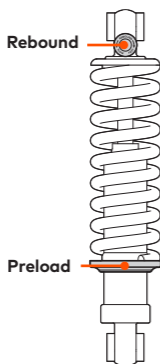

5. YOUR BATTERY

The UBCO 2X2 battery and connections are made to do the hard work. Tested to an IP66 standard, the battery is fully water and dust resistant. A solid work horse, the Li-ion battery delivers a large capacity in a sturdy package.

Each 2X2 battery is constructed from high quality LG 18650 Cylindrical Cells, mounted into cell holders, sealed within an alloy case, and screwed shut.

They are UN38.3 certified and the charger is UL/CE certified to provide safe operation, use, and transit. All this results in a robust battery that can handle the ride – and all the mud and dust.

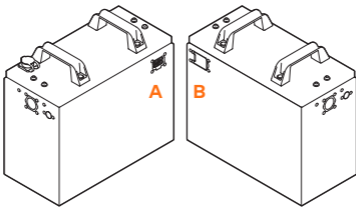

- A. Main Power Output
- B. Charge Socket

When placing the battery into the bike, ensure the main power output socket is located on the right-hand side of the battery (when sitting on the 2X2). The charge port is located opposite side. Be sure the plugs and ports are clean before attaching.

5.1 Charging

Depending on capacity and remaining charge, the battery can take up to 6 hours to fully charge.

5.2 Checking the charge

To check battery capacity, ensure it is plugged in to the 2X2 and press the key fob to turn the bike on. The charge meter on the left hand side of the LCD display will indicate the remaining charge level. Charge level is also available on the UBCO App.

The yellow 'Charge Required' light at the top of the display will also illuminate when the charge is low.

Fold out the User Manual to continue reading. 

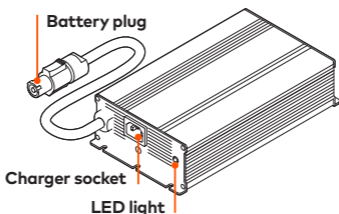

5.3 How to charge the battery:

- A. Turn off the 2×2 using the key fob.
- B. Plug the charger into the charge socket on the battery and twist to lock.
- C. Plug the provided charger into any standard wall socket and switch on at the wall (where required).
- D. The LED indicator lights on the charger will signal:

Green: Battery is fully charged

Red – Solid: Charging as normal

Red – Flashing: No battery connected

Blue – Solid: Battery voltage fault

Blue – Flashing: Reverse polarity

If a charge error occurs, disconnect the charger from the battery and wall socket. Reconnect. If flashing persists, contact your UBCO dealer.

When charging:

- Keep away from any sparks or flames.
- Install a smoke alarm near your charging area. Do not charge if cables, charger, or battery are damaged.
- Use charger in dry, indoor conditions only and with adequate ventilation.

When finished charging:

- Replace the waterproof cap over the charging socket on the battery.



WARNING: Only use the charger under cover and on a clean, dry surface; the charger is NOT water resistant.



Never store the battery in an uncharged state. Doing so can void the warranty.

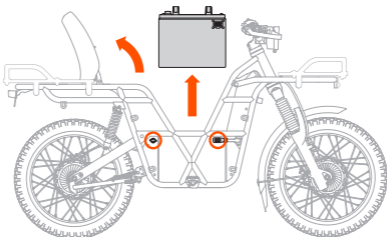

5.4 Removing the Battery

The 2X2s battery is interchangeable with other GenX5 2X2 batteries, meaning that if you have more than one, you can swap them out to avoid charging downtime. Extra batteries are available from UBCO Ltd or your UBCO dealer.

- A. Turn off the 2X2
- B. Lift the seat. Remove centre totte bag if installed.
- C. Remove the battery strap and power plug.
- D. Using the securing key, unfasten the lock located on the rear right-hand side of the battery.
- E. Lift the battery with two hands.
- F. Store on a stable, cool, dry surface.



HEAVY OBJECT. The batteries weigh between **14-18kg / 30-40lbs.**

To avoid muscle strain or back injury, use proper lifting techniques when moving.



To operate properly, the **plug and sockets** need to stay **clean** and in **good condition**. If the battery is removed, ensure that the battery plug is reinstalled correctly.

5.5 Battery Care & Safety

The lithium-ion battery and charger are designed to work exclusively with the 2X2. Do not attempt to use any battery or charger other than those supplied by UBCO. Extra batteries and chargers can be purchased from UBCO Ltd or your UBCO dealer.

- Lithium-ion batteries do not suffer from the same charge memory problems as other batteries, therefore they can be topped up at any time.
- Charge your battery at least once a month to ensure its health.

- Secure the battery in place when riding.
- Do not drop the battery into the 2X2 from a height. Lower it into place carefully.
- Do not submerge the battery or the 2X2.
- Store in a cool place indoors when not in use.
- Do not burn the battery or place it near heat sources above 80°C / 176°F.
- Keep away from children.
- Do not attempt to open the battery. This will void the warranty. If you have any issues, please contact your service provider.
- Always charge your 2X2 indoors and at a temperature between 0-40°C / 32°-104°F. Charging the battery outside of this temperature range could damage your battery or affect performance and life span.
- As lithium is deemed a Class 9 Dangerous Good, the battery must always be charged on a non-flammable surface (on a concrete floor, steel shelf, etc).
- If storing for an extended period, ensure the battery has between 50% and 90% charge. Storing the battery with either full or too low a charge can cause cell damage, reducing its life.

6. RIDING SAFETY

Due to its electric drive motors, the UBCO 2X2 is silent when on and very quiet in operation. When not in use, be sure to turn the bike off to prevent accidental activation of the throttle.

The electric drive eliminates many of the inherent safety concerns associated with internal combustion motorcycles.

6.1 General Safety

- The 2X2 is nearly silent, always assume you are invisible to all other road and off-road users. Your life depends on it.
- Be aware of your surroundings, other people, animals, and other vehicles. Ride to the conditions.
- Ride the 2X2 within its loading and gradient limits as described in this section.
- Follow your local riding laws and regulations and ride within your limits.

- Never operate the 2X2 when fatigued, impaired, or under the influence of drugs or alcohol.
- Wear a well-fitting helmet, securely fastened, that provides good visibility and meets law requirements.
- Wear appropriate apparel such as close-toed shoes, gloves, and eye protection.
- Only one person should ride the 2X2 at any one time.
- Inexperienced riders must take care.
- Children should NOT operate the 2X2
- Watch for changes in terrain.
- Abide by local off-road riding laws and regulations.
- Use your horn as a warning signal where appropriate.
- Do not 'wheelie' or jump the 2X2. This can damage the hub motors, causing gear shock when the motor accelerates rapidly in the air and then decelerates instantly when it hits the ground again.
- The 2X2 is not designed to be a MX/Motocross bike. Using the 2X2 like an MX bike may damage the drive system and will likely void the warranty.
- The battery, motors, and electrical components are protected against mud, heavy rain, surface water, and shallow water crossings. They are not protected against submersion. The 2X2 should not ford water deeper than the axles.

If you are unsure about the type of riding you are doing, please check with your service provider or the team at UBCO and we can advise you.

6.2 Kickstand Safety

The UBCO 2X2 comes with a manually retracted kickstand that must be retracted before riding. When retracting the kickstand, it is important to keep your legs and other body parts clear of the kickstand's path of movement.

7. LOADING THE 2X2

7.1 Loading Safety

Improperly loading your 2X2 can affect its stability and handling. Ride with caution when your 2X2 is loaded up.

We recommend you do not exceed 150kg, including your body weight and cargo. Do not put your full weight on the kickstand. It is rated to support the 2X2 and a 50kg load. If load exceeds 50kg, support the 2X2 while loading.

Balance your load evenly. Do not impede any moving parts on the 2X2. Do not obscure lights, suspension, steering, or the view from your wing mirrors.

NOTE: These load limits are estimated suggestions based on testing. Each rider's abilities and limitations should be considered when loading up the 2X2

Rider Only $\leq 100\text{kg}$

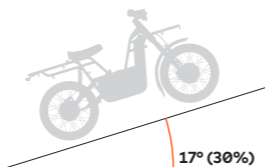

Rider + Cargo $\leq 100\text{kg}$

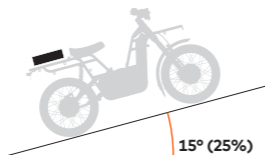

Rider + Cargo 100-150kg



Load Limits

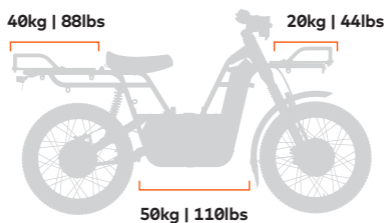

7.2 Riding with a load

With a load up to 100kg / 220lbs, the max gradient is 15%/25%. With loads exceeding 100kg, maximum and continuous gradients must be reduced accordingly.

Estimated limits for various gradients are illustrated here. For perspective, Baldwin Street in Dunedin, NZ is the world's steepest street at 19° or 35% – so don't be afraid to tackle those hills!

7.3 Carrying the bike

The 2X2 can be carried on a vehicle using a standard tow hitch-mounted carry rack.

- A. Remove the battery before transporting and carry batteries inside your vehicle.
- B. Lift the bike onto the rack and lock steering to avoid excess movement while travelling.
- C. Attach ratchet straps around both the towbar rack and the 2X2 frame through the center section of the bike (where it forms an X shape).
- D. Check the bike is secure before driving your vehicle.
- E. Ensure plugs and ports are clean before reinstalling the battery.



HEAVY OBJECT – 2 PERSON LIFT REQUIRED.

Bikes weigh between **50-53kg / 110-116lbs** with the battery removed.

To avoid muscle strain or back injury, use proper lifting techniques when moving.

8. ALERT CODES

Your 2X2's intelligent electronics system provides valuable information while you ride, displayed on the LCD dashboard and/or the UBCO rider's app. This system alerts you of any issues or concerns (often temporary) so we recommend regular checks to ensure your 2X2 is operating as effectively and efficiently as possible.

There are two types of codes:

- **Cautions:** These start with C-XXXX and are labeled as cautionary as they will not stop the bike from operating. They still require attention, as the bike may no longer meet safety or compliance standards.
- **Faults:** These start with F-XXXX and relate to a specific fault on the bike that may lead to incorrect operation. They require immediate attention and may require servicing by an UBCO-certified technician.

In addition, the first digit of the code indicates if applicable to the front or the rear of the bike:

- **Front:** Codes start with either C-**1**XXX or F-**1**XXX.
- **Rear:** Codes start with either C-**2**XXX or F-**2**XXX.

This table provides a list of potential codes and the recommended remedial actions.

Lighting Systems

C-0001, C-0002, C-0004, C-0005 C-0006

Carry out basic inspections.⁽¹⁾

If fault persists, contact your local service agent.⁽²⁾

Battery Systems

C-1058, C-2058, C-1061, C-2061, F-1011, F2011

Carry out basic inspections.⁽¹⁾

If fault persists, contact your local service agent.⁽²⁾

Hub Motor/Controller System

C-1062, C-2061, C-1063, C-2063, F-1001, F2001, F-1015, F2015, F-1026, F-2016, F-1017, F-2017, F-1018, F-2018, F-1028, F-2028, F-1052, F-2052, F-1053, F-2053, F-1056, F-2056, F-1057, F-2057, F-1064, F-2064

Carry out basic inspections.⁽¹⁾

If fault persists, contact your local service agent.⁽²⁾

Throttle/ECU System

C-0011, F-0001, F-0003, F-1024, F-2024

Carry out basic inspections.⁽¹⁾

If fault persists, contact your local service agent.⁽²⁾

Impact/Shock to wheel

F-1022, F-2022

These codes can be caused by an impact or shock loading to a wheel.

Cycle power to clear fault memory and continue riding.

If fault persists, contact your local service agent.⁽²⁾

High Motor Temperature

F-1023, F-2023

These codes can be caused by the hub motors becoming excessively hot.

Stop riding and allow motors to cool before continuing on.

If fault persists, contact your local service agent.⁽²⁾

⁽¹⁾ **Basic Inspections:**

- Check and confirm charge level of the battery.
- Check battery connection for cleanliness and security.
- Visually inspect relevant components for damage or signs of wear and tear.
- Inspect relevant wiring harnesses and connectors for damage.
- Check/update firmware using the UBCO rider's app.
- If you're unsure about anything contact your local service agent or support@ubcobikes.com.

⁽²⁾ **Visit: www.ubco.com/dealer-locator** for a full list of UBCO Service Agents.

TECHNICAL INFORMATION

SPECIFICATIONS	METRICS	IMPERIAL
Drive Train	2 x 1kW motors	
Weight (excl Battery)	58.7kg	132lbs
Height	1,825mm	48.4in
Seat Height	815mm	32in
Width (Handlebars)	846mm	33in
Length	1,820mm	72in
Wheelbase	1,215mm	47.8in
Payload (incl rider)	158kg	350lbs
Suspension - Front	130mm adjustable	5.12in
Suspension - Rear	120mm adjustable	4.72in
Range (Max Tested)	128km	79mi
Max Speed	58km/h	36mph

VEHICLE CLASS

- WMC PIN coded off road vehicle. NOT road registrable:
- CE Compliant for off-road use in Europe. Can be registered as a farm/work vehicle in some European jurisdictions.
 - RVCs approved for off-road use in Australia.
 - Compliant for off-road use in NZ.

Note: Check your local licensing laws to determine license requirements. All information in this publication is based on the latest production information available at the time of approval for printing. UBCO Ltd reserves the right to make changes at any time without notice.

ACCESSORY LUGS

The 2X2 features 19 individual accessory lugs that are strategically placed across the frame to provide flexibility and adaptability. The lugs use standard M8 nuts and bolts for attaching tie downs, mounts, and accessories. Inside each lug is a cavity to hold an M8 nut in place, preventing it from spinning as the bolt is tightened or loosened.

The front rack is attached via two lugs at the front of the main frame. These lugs can be utilized for other attachments when the front rack is removed.

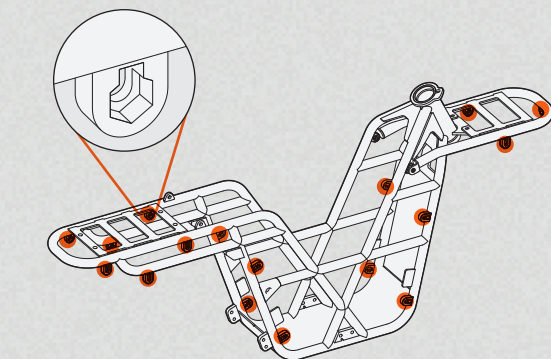
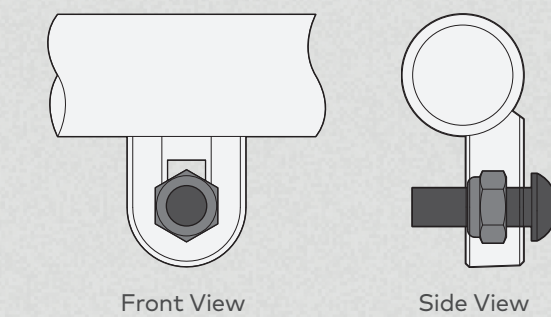

SUSPENSION RECOMMENDATIONS

	FRONT REBOUND	FRONT SPRING	REAR REBOUND	REAR SPRING
Hard Ground Rider Only (90kg)	Max fast	Full soft	Max fast	28mm thread exposed
Hard Ground + Load (125kg)	Max fast	1 full turn to hard	4 clicks towards slow	28mm thread exposed
Soft Ground Rider Only (90 kg)	Max fast	Full soft	2 clicks towards slow	38mm thread exposed
Soft Ground + Load (125kg)	Max fast	1 full turn to hard	6 clicks towards slow	38mm thread exposed

Note: Hard Ground refers to dry tracks; soft ground might be tall grass, mud, or sand.

WHEELS

Each tire on your 2X2 uses a standard, car style valve for inflation and deflation.

The 9-gauge stainless steel spokes in a tangential double-crossed pattern provide extra wheel strength on DOT compliant aluminum rims.

Tires: Supplied with 17x2.75" off-road knobby tires. Only use tires with a minimum load capacity of 37 and minimum speed category of B.

Recommended Tire Pressure: 207 kpa | 25 psi or as specified on the tire.

MEASUREMENTS

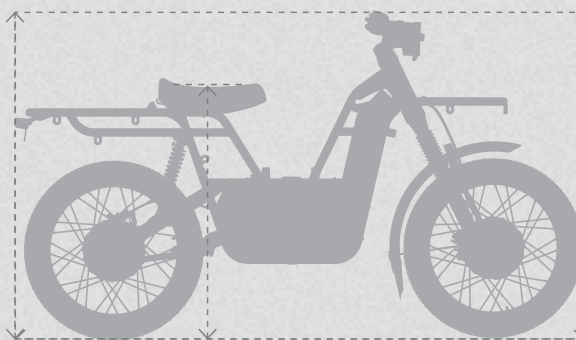

LENGTH: 1.8m | 6ft
WIDTH: 0.84m | 33in
WHEELBASE: 1.2m | 4ft
HEIGHT: 1.02m | 3.37ft
SEAT HEIGHT: 0.8m | 32in

Key Features Of Your 2X2 Electric Motorbike

2024 HUNT EDITION

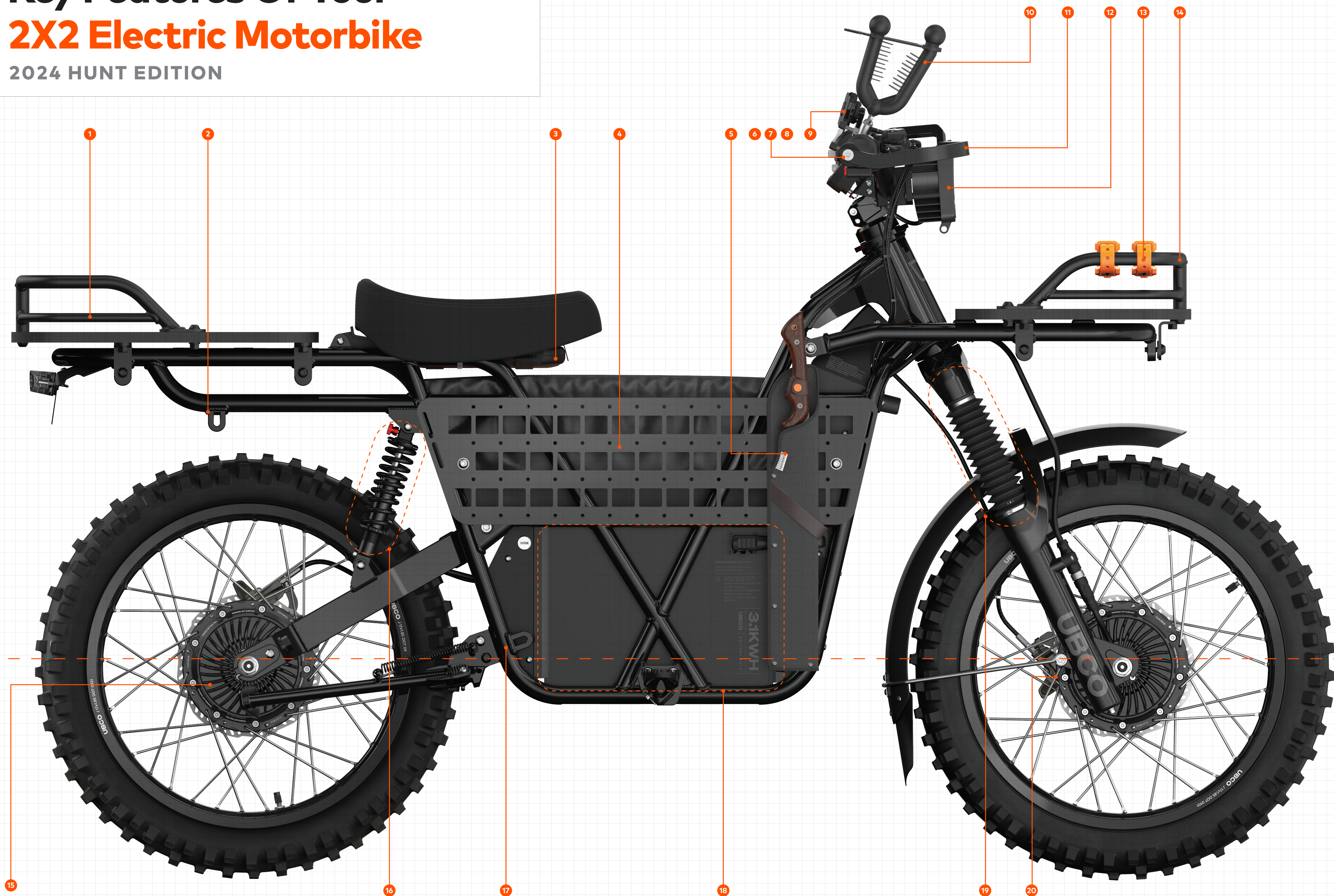

- 1 REAR CARGO DECK**
Designed with strength in mind, it allows you to increase your carrying capacity. Removable dual aluminum rail. Inside carry area: 450mm x 405mm. Recommended max carry weight 88lbs | 40kgs.
- 2 ACCESSORY ATTACHMENT LUGS**
19 drop forged attachment lugs conveniently located around the bike frame & racks. Fit UBCO accessories or use the adapter pack to create your own custom attachments.
- 3 FIELD KIT (UNDER SEAT)**
Includes a small set of tools, user manual, and spare keys.

- 4 MOLLE PANELS**
The modular Molle panels allow endless configurations of storage options depending on your needs.
- 5 BAREBONES MACHETE**
Japanese Nata Tool- clear brush, strip bark, plank wood, make kindling-all with one thoughtfully-crafted tool.
- 6 LCD DASH AND RIDER APP**
See your vital riding stats at a glance. Use the UBCO Rider App to customize your ride settings.
- 7 SECURE KEYLESS OPERATION**
The keyless fob for on/off utilizes code hopping technology which resists cloning and hot wiring.

- 8 USER FRIENDLY CONTROLS**
With no clutch, momentary switches for instant feedback, and electronic throttle control, riding is intuitive and easy. Just twist the throttle and go!
- 9 PEAK DESIGN PHONE MOUNT**
A versatile, phone mount that is durable, adjustable, and easy to use.
- 10 BOW/GUN MOUNT**
Full 360-Degree rotation will custom fit different sized equipment from hunting raffles, bows, fishing rods, and shovels.
- 11 LEVER GUARDS**
Aluminum lever guards keep your handlebars & controls protected if the bike falls over.

- 12 LED LIGHTS**
Powerful 2400 lumen floodlight headlight. Compact and lightweight. Environmentally sealed.
- 13 GIANT LOOP PRONGHORN STRAPS**
Tough multi-purpose stretch straps provide full flexibility to attach and carry your equipment and gear.
- 14 FRONT CARGO DECK**
Designed to expand your load carrying capacity on the front of your UBCO 2X2. Removable dual aluminum rail. Inside carry area: 450mm x 305mm. Recommended max carry weight of 44lbs | 20kgs.

- 15 SILENT MOTORS**
2x 1kW Hub Motors
Max speed: 30mph | 50kph
Near silent motors let you enjoy the sounds around you without adding any noise pollution of your own.
- 16 REAR SUSPENSION**
120mm Adjustable Rebound Controls. Spring preload adjustment.
- 18 SUPER X STRUCTURE**
Step through frame made from 7027 series aluminum alloy. Total payload including rider and cargo: 330lbs | 150kgs.

- 17 HIGH CAPACITY LITHIUM ION BATTERY**
Sturdy alloy case, weatherproof to withstand rain and washing. Intelligent battery management system (BMS) keeps your battery in good health. Multiple safety mechanisms designed in.
- 19 FRONT SUSPENSION**
130mm Adjustable Rebound Controls. Spring preload adjustment.
- 20 REGENERATIVE BRAKING**
UBCO regen braking system enables the motors to do some of the braking work, saving brake pad wear, and helping recharge the battery at the same time.
- 1 MAX SUBMERSION DEPTH**
Do not submerge the 2X2 above the axles. This could damage the bike and void the warranty.



DESIGNED IN NEW ZEALAND.
BUILT FOR ADVENTURE.

DESIGNED FOR DISASSEMBLY.
BUILT FOR THE PLANET.

DESIGNED FOR FUN.
BUILT TO LAST.

