

2X2

2018 USER MANUAL



HELLO.

Congratulations on your new UBCO 2×2.

First things first – register your 2×2 as soon as possible using our online registration form. You can find the registration form on our website at:

www.ubcobikes.com/register

Step 2: Record your VIN number in this booklet (at right) and attach your receipt of purchase for safekeeping.

Step 3: Download The UBCO 2×2 App.

You can download either the iOS or Android App to control the settings of your 2×2 and get critical updates to your 2×2 delivered wirelessly.

Simply search UBCO in the Apple App Store or Google Play Store.

Vehicle Identification Number

For easy reference, record your Vehicle Identification Number (VIN) here. It is stamped on the right-hand side of the frame head tube.

--	--	--	--	--	--	--	--	--	--	--	--	--	--	--	--	--	--	--	--	--

Find UBCO online:

ubcobikes.com

fb.com/ubcobikes

instagram.com/ubcobikes

youtube.com/ubcobikes

TABLE OF CONTENTS

01 ABOUT YOUR 2×2

2×2 Dual Electric Drive	4
Cerebro Control System	4
Portage Power System	4
Flux Drive	4
Quadratic Brake System	6
Super X Frame	6
UBCO Wheelset	6
All Terrain (AT) Suspension System	6
Steering Lock	8
Motor Cut-off Switch	8
Seat	8
2×2 Accessory System	8
Console	8
User Controls	8
Wiring	8
Lighting	10
Display	10

2

Connectivity and User Input	10
Kickstand	10
Technical Specifications	16

02 GETTING STARTED

18

Pre-ride Inspection	19
General Riding	19
Riding in the Wet	19
Turning on Your 2×2	20
Headlight Control	20
Handlebar Controls	21
Safety Cut-off	21
Steering Security Lock	22
Adjusting Your Mirrors	22
Throttle	23
Brake	23
Your Display	24
Kickstand	26
Adjustable Suspension	26

03 YOUR POWER PACK 28

- Removing the Power Pack 29
- Charging Your Power Pack 31
- Checking Power pack Charge 31
- Charging Powered Devices 32
- Power Pack Care & Safety 33

04 SAFETY 34

- Riding Safety 35
- Lights 37
- Loading the 2x2 38

05 ACCESSORIES 40

06 MAINTENANCE & CARE 46

- Cleaning 47
- Wheels 48
- Removing Front Mud Guard 50
- Replacing Brake Pads 51

07 COMPLIANCE 52

- Vehicle Compliance 53
- FCC Compliance 53

01

**ABOUT
YOUR 2X2**

The UBCO 2018 2×2 is a two wheel drive utility electric vehicle (UEV). It is dual use and comfortable both on- and off-road. It has been designed and engineered for work and play with a large wheel diameter, full suspension, and allows you to adapt the 2×2's settings to different applications.

This section gives you a detailed overview of the 2×2 and its functions and features.

Please read this owner manual carefully; it outlines everything you will need to know when owning a 2018 UBCO 2×2. Pay special attention to the safety messages that appear throughout the manual.

This manual should be considered a permanent part of the 2×2 and should remain with the 2×2 if it is resold.

All information in this publication is based on the latest production information available at the time of approval for printing. UBCO Ltd reserves the right to make changes at any time without notice.



When you see this symbol, the information following is important for safety and proper function of the 2×2.

2×2 Dual Electric Drive

The UBCO 2×2 is dual electric drive. Two-wheel drive delivers improved handling and tracking in a wide range of ground conditions, both on- and off-road.

Cerebro Control System

All new for the 2018 2×2 is the Cerebro Electronic Control Unit (ECU) which talks to all areas of the 2×2. It controls the lighting, talks to the display and motor controllers, provides an audible sound for the indicators, and enables Bluetooth connectivity to the 2×2 to customise the riding experience. It will ultimately offer a range of upgrades to the 2×2 that will be rolled out.

Portage Power System

The Portage Power System is a 48Ah rated, 50V lithium-ion portable power pack (battery) which not only powers the 2×2, but also allows the user to charge their devices and tools. This specially designed power pack provides an effective riding range per charge and has a charge time of 6-8 hours.

The 2×2's portable power pack has a secure locking plug which secures it to the 2×2 , preventing it from being removed by opportunists.

The power pack comes with a wall charger that is designed to be plugged into a 100-240V AC 50/60 Hz outlet only. The power pack is interchangeable and can be removed from the 2×2 simply by unscrewing the lock and unplugging it. To find out how to charge the 2×2, see Section 03: Your Power Pack.

Flux Drive

The 2018 2×2 delivers the innovative new Flux Drive. The drive internals have been beefed up to allow more power to be pushed into them and the enclosure has a new sealing system to deliver a drive capable of surviving in tough, hard working environments, where exposure to mud and water are constant. The drives are engineered to use regenerative braking which will assist brake performance. We have also developed a novel heat sink that improves efficiency and heat shedding from the drive core.



Directional indicators, reflectors, rear light, number plate holder and mirrors on the road version only.

Quadratic Brake System

We have developed the brake system with large diameter DOT approved brake lines and fittings, as well as sensor switches that are connected to the ECU and electrical system. The brakes work in conjunction with the ECU, controllers, and Flux Drives to provide assisted braking that uses the motors in addition to the brake system to provide ultimate stopping power. There are several brake pad options depending on your environment with sintered pads recommended for heavy mud, sand, and volcanic pumice.

Super X Frame

The unique frame is designed for strength and stiffness while remaining light weight. Constructed from 7000 series aluminium, the frame has excellent corrosion resistance. It has a fixed rear carrier, removable front carrier, and lugs for carrying cargo. For full loading limits and guidelines see Section 05: Accessories. The 2x2 is equipped with a large head tube, allowing for the UBCO front suspension fork, which uses a tapered steering tube design for improved stiffness.

UBCO Wheelset

The Flux Drives are laced into the all new UBCO wheelset. Two 17 x 1.85" DOT aluminium rims are wrapped in 17 x 2.75" multi-terrain tyres, providing an excellent balance between street comfort and off-road grip. A wide range of tyre options are available for your different applications with full off-road knobbles available.

All Terrain (AT) Suspension System

With the 2018 2x2 comes the innovative UBCO ATFZ Front Fork, with beefy die cast aluminium lowers and 37.5mm chrome plated steel stanchions, designed to provide a smooth ride. Complete with torque arms and 130mm travel, this fork was built with front wheel drive in mind. The rubber fork boots fit perfectly to the stanchions to keep out all unwanted gunk. The rear suspension is 32mm UBCO ATR shocks with adjustable spring preload and rebound damping with 120mm of travel.



Directional indicators, reflectors, rear light, number plate holder and mirrors on the road version only.

Steering Lock

The 2×2 includes a custom steering lock configuration so that the wheel of the 2×2 can be locked at a +20 degree angle when parked. This provides added security, as the 2×2 cannot be simply wheeled away.

Motor Cut-off Switch

The 2×2 is home to a motor cut-off switch, located on the right-hand side of the handlebars, beside the brake lever mount.

Seat

The 2×2 has a large cushioned seat to provide a comfortable platform for the rider to sit on. It fastens to the frame via two plastic spring clips and lifts to allow you to remove the power pack from the frame. Ensure the clips are securely engaged on the frame before operating the vehicle.

2×2 Accessory System

There are 17 accessory lugs built into the frame to provide solid mounting points for accessories. Three of these lugs are available on the front carrier. These lugs fit standard M8 bolts and contain a

cavity in the back to house an M8 nut, preventing it from spinning as the bolt is tightened or loosened.

The lugs are strategically placed on the frame to provide maximum flexibility, facilitating the attachment of large and small items. Ensure all nuts are securely tightened and loads are strapped down before riding the 2×2.

Console

The front console of the 2×2 houses the ignition, as well as a 12V power output and two USB ports, allowing you to charge your devices directly from the 2×2.

User Controls

The 2×2 has an all-in-one handlebar control on the left side that controls the horn, high and low beam light, and direction indicator lights, keeping the right hand focussed on the throttle.

Wiring

The 2×2 has a wiring design which minimises the additional wiring required for road going lighting. With IP66 rated connections and a modular design, the 2×2's wiring design keeps visual disruption to a minimum while maximising serviceability.



Directional indicators, reflectors, rear light, number plate holder and mirrors on the road version only.

Lighting

The 2×2 makes use of low energy LED lighting for all lighting sources. The 2×2's headlight has both high and low beam modes for maximum visibility, both on the road and the track. On high beam, the headlight is a 36W light, providing 2,230 lumens. On low beam, it's 27.6W, providing 1,220 lumens.

The rear light incorporates the tail light, brake light, and number plate illuminating light into one unit.

Display

The 2×2's display houses an FSTN transmissive panel with a warm white backlight for optimal day and night viewing. The display makes keeping track of your riding easy and shows all the important information, including speed, power pack level, odometer, trip meter, motor temperature, real-time power output, and the time. The display can switch between metric and imperial units to suit your requirements. Tell-tale lights indicate warnings, a low power pack, directional indicators, the headlight, and an illuminated "N" light when the 2×2 is in a neutral and non-ridable mode.

Connectivity and User Input

Not only can the 2×2 charge your USB and 12V socket devices, but you can now talk to the 2×2 with your smart phone or other Bluetooth-enabled devices.

Kickstand

The UBCO 2×2 is equipped with a retractable, spring loaded kickstand on the left side of the 2×2. For more information on the kickstand, see Section 02: Getting Started

Warning: Modifications

We strongly advise that you do not remove any original equipment or modify the 2×2 in any way that would change its design or operation. The 2×2 has been designed in a way that makes it safe for all users; changing this intention could result in injury both to riders and those around you. If you are to adapt the 2×2 for your needs, use only the lugs and carriers provided and follow safety instructions.

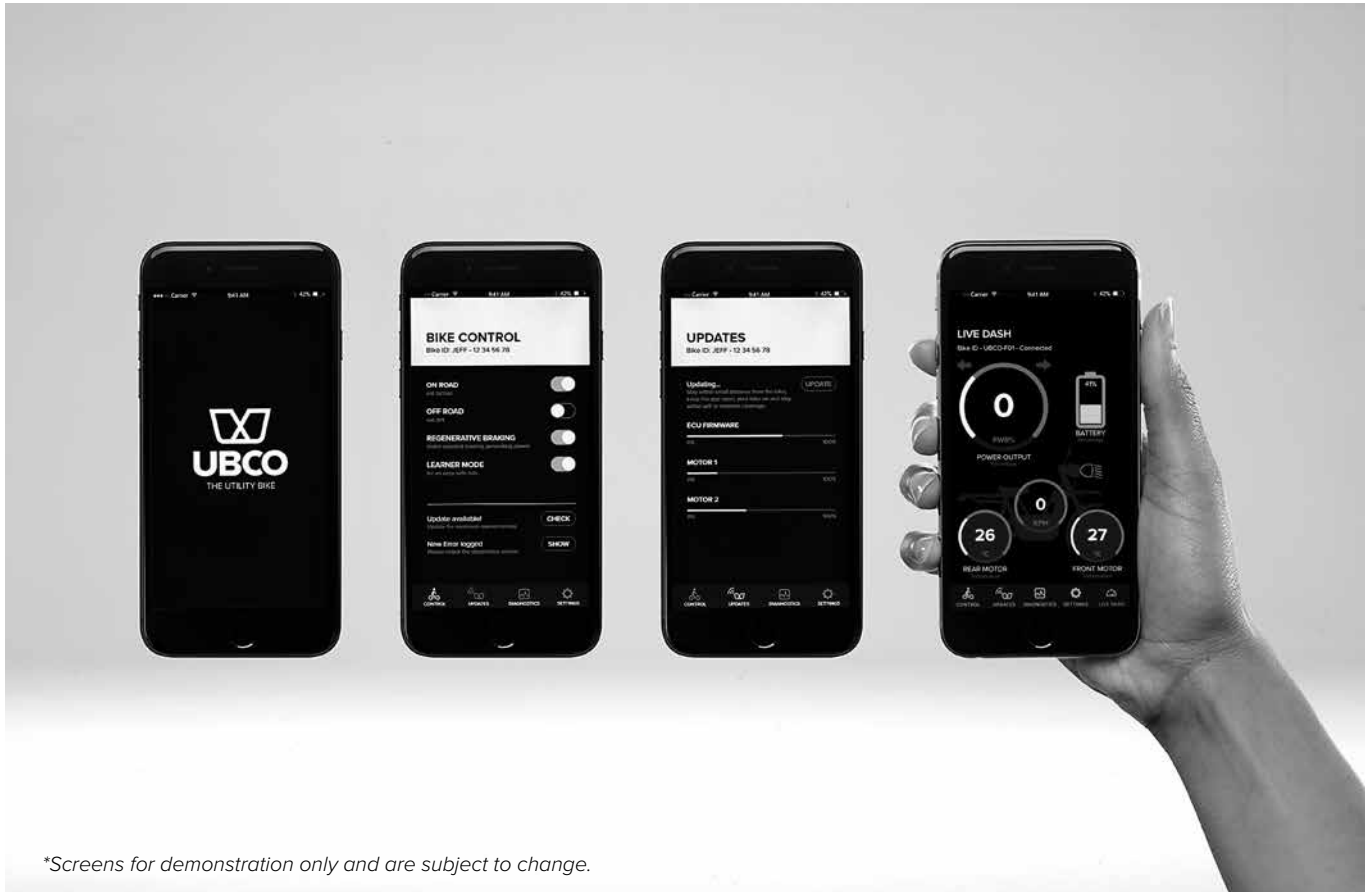

**Screens for demonstration only and are subject to change.*

2X2

2018

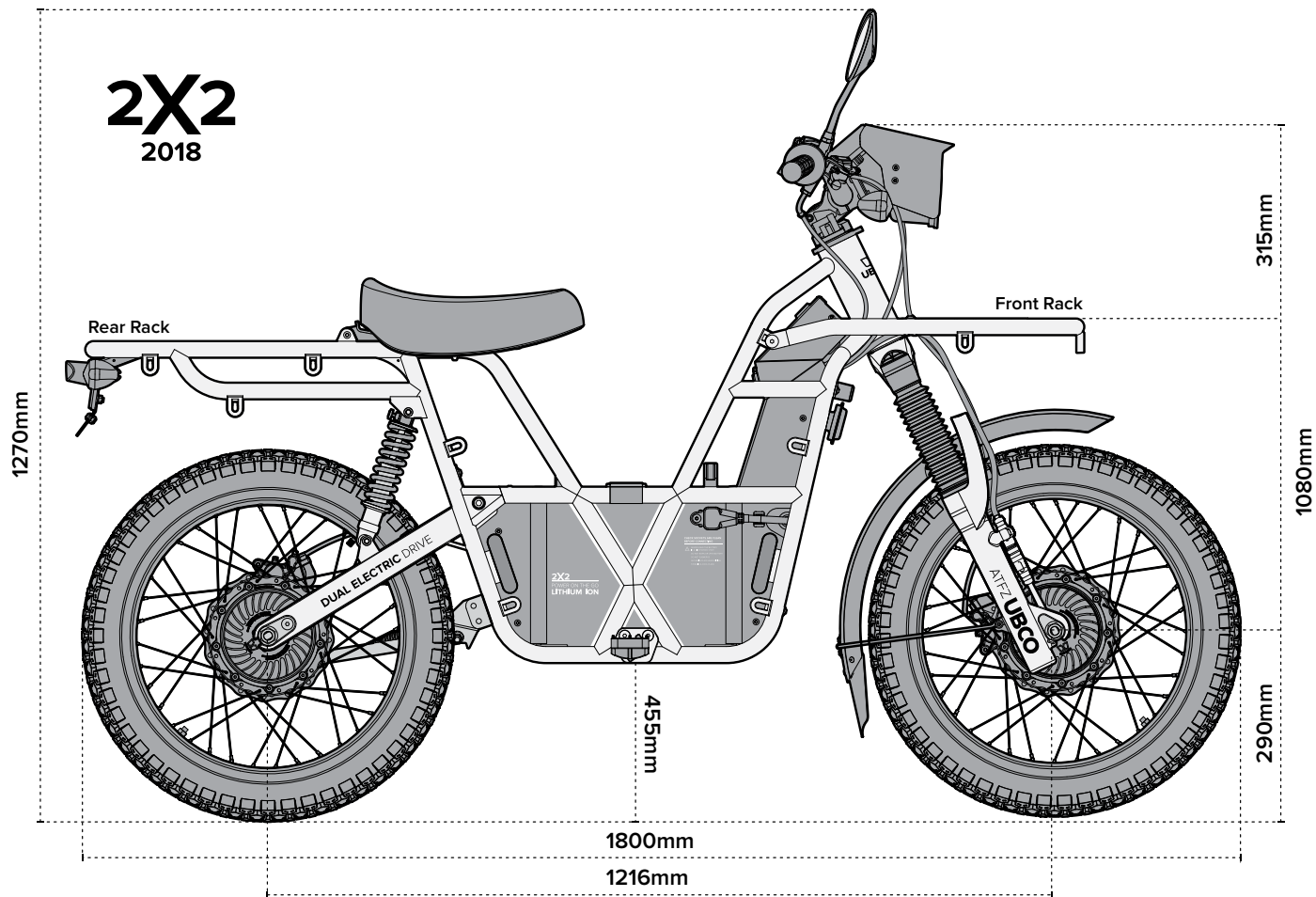

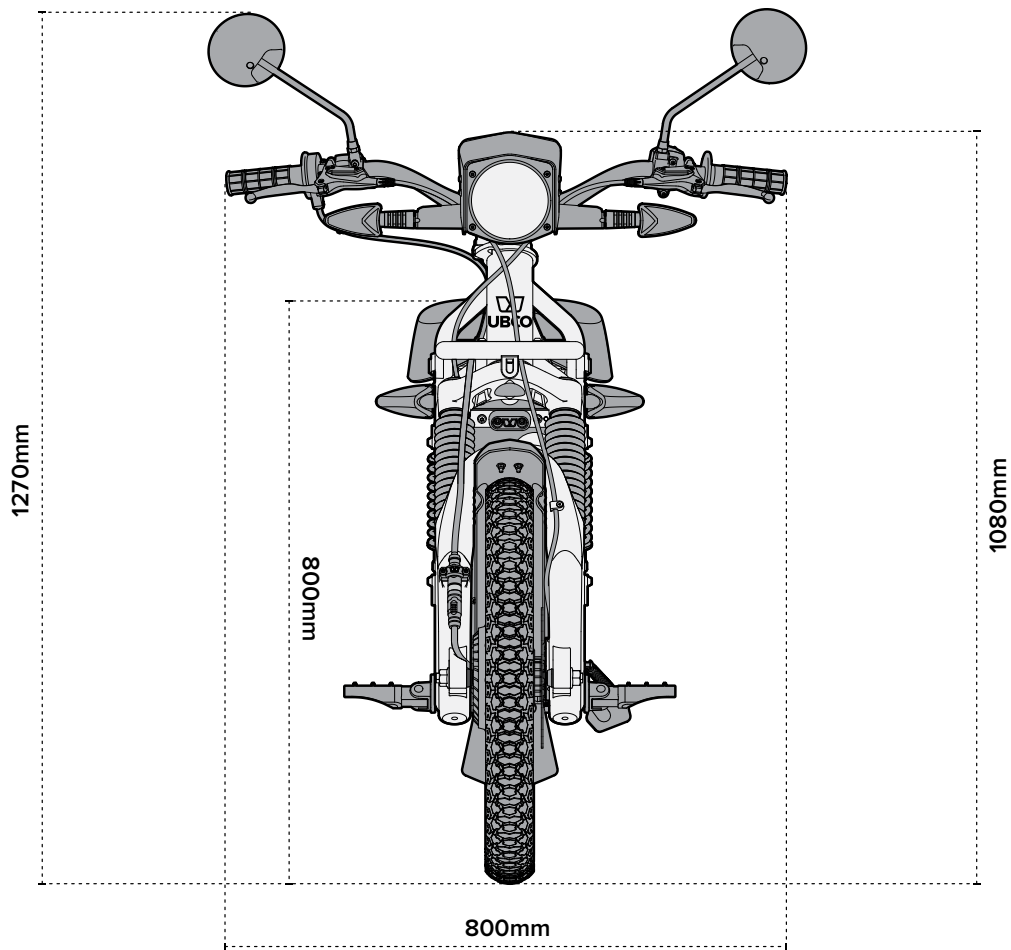

Directional indicators, reflectors, rear light, number plate holder and mirrors on the road version only.

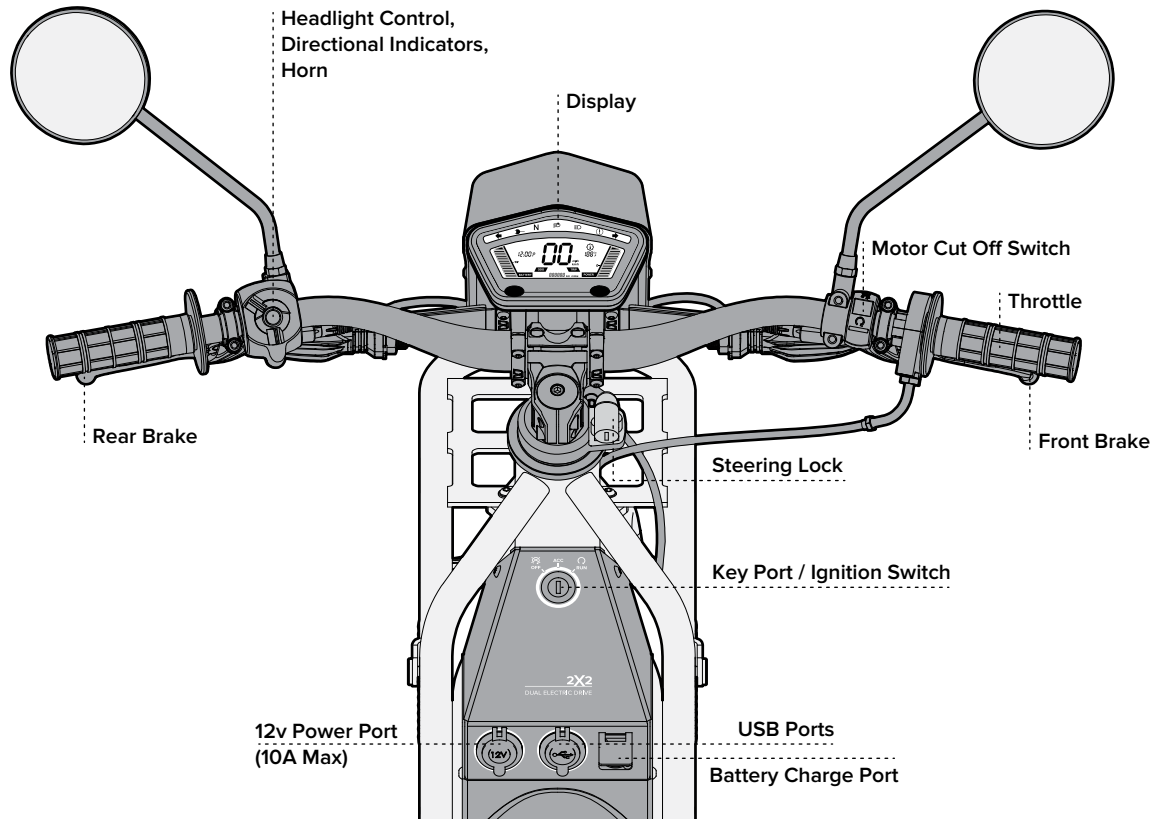

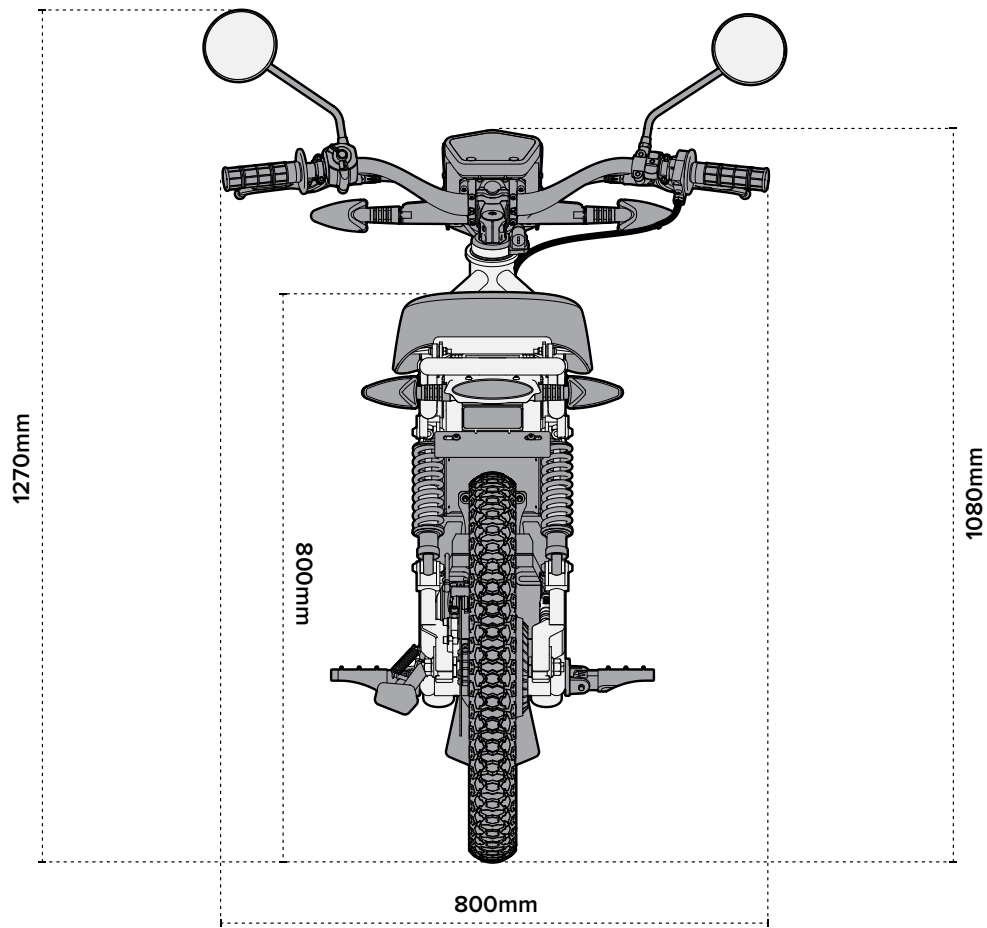

Directional indicators, reflectors, rear light, number plate holder and mirrors on the road version only.

Technical Specifications

DIMENSIONS

Height* (excl mirrors)	1,050mm	42"
Length* (excl number plate)	1820mm	72"
Width (handlebars)	800mm	31.5"
Wheel base	1,200mm	47"
Seat height	800mm	31.5"
Curb weight	63kg	139lbs
Carry capacity (incl rider)	150kg	330lbs

ELECTRICAL SYSTEM

Motor	2x 1kW brushless DC air cooled hub Flux Drive motors
Controller	2x high power density controllers with over-heating protection
Power pack	UBCO lithium-ion 52.2Ah (48Ah rated) 50V battery
Charger type	100-240V 350W wall or bench mount
Charge time	6-8 hours
Input	Bluetooth with user app/USB
Ports	2x USB charging ports (1A & 2.5A) 1x 12V outlet (10A max)

COMMUNICATION

Integrated ECU	Directly controls lighting, motor controllers, display, rider controls, Bluetooth connection
----------------	--

DRIVETRAIN

Transmission	Single Stage Planetary Gear Reduction Integrated radiator for enhanced heat dissipation
--------------	--

CHASSIS / SUSPENSION / BRAKES

Front suspension	37.5mm custom UBCO front fork with rebound adjustment
Rear suspension	32mm shock with adjustable spring preload and rebound damping
Front suspension travel	130mm
Rear suspension travel	120mm
Brakes	Tektro Dorado front and rear brakes, 203 x 2.3mm rotors, high power hydraulic callipers
Wheels	17 x 1.85" aluminium rims 17 x 2.75" Kenda K667 tyres

LIGHTING

LED Headlight	120mm	4.75" diameter
Low beam	1330 lumens	27.6W
High beam	2230 lumens	36W
Additional lighting	LED rear, brake, number plate and directional lights	

PERFORMANCE

Range	Max range varies depending on terrain and carry load	
Power	2.4kWh	
Torque	184Nm	
Top speed	50km/h	30mph

VEHICLE CLASS

NZ/AUS	LA (moped)
US	Motor driven cycle or moped
EU	L1Be

WARRANTIES

Dual-use 2018 2x2	12 months
Portage Power Supplies	24 months
Accessories	12 months
Spare Parts	6 months

**Height / Length measures are approximate.*

Directional indicators, reflectors, rear light, number plate holder and mirrors on the road version only.

All product specifications are subject to change without notice to improve performance, function and/or design.

02

GETTING STARTED

Everything you need to know to start your UBCO 2×2 journey.
We advise that you read through all the information in this manual before you take your 2×2 out for the first time.

Pre-ride Inspection

You should perform a pre-ride inspection each time you ride to ensure all parts are in full working order.

Mentally check off each of the following before riding the 2×2:

- Lights** – Ensure the headlights, rear light, brake light and directional indicators are working.
- Power pack** – Ensure there is enough charge to carry out your work or journey. Ensure the power pack strap is secured tightly.
- Tyres** – Check the condition and pressure of the tyres. Tyres are interchangeable and can be swapped out if required (details in Section 06: Maintenance & Care).
- Brakes** – Check they are operational and check the brake pad wear.
- Mirrors** – Check they are adjusted for proper viewing and are not obstructed by any load you may be carrying.
- Horn** – Check it sounds.
- Loose nuts, bolts, or fixings** – Ensure all are done up correctly and are secure.

General Riding

Do not ‘wheely’ or jump the 2×2. This can damage the hub motors, causing gear shock when the motor accelerates rapidly in the air and then decelerates instantly when it hits the ground again.

The 2018 UBCO 2×2 is not designed to be a Motocross (MX) bike. Rather, it has been designed to be lighter and more functional. Using the 2×2 like an MX bike may damage the drive system and will likely void the warranty.

If you are unsure about the type of riding you are doing, please check with your service provider or the team at UBCO and we can advise you.

Riding in the Wet

The power pack, motors, and electrical components are protected against mud, heavy rain, surface water, and shallow water crossings. They are not protected against submersion and the 2×2 should not ford water deeper than the wheel axles.

When riding on the road in wet weather, be sure to drive to the conditions.

Turning on Your 2×2

First things first, you need to turn the 2×2 on. It's important to remember that the 2×2 is very quiet due to its electric drive motors, and will not rev when it's turned on.

The 2×2 is equipped with a three-stage key switch. To start, insert your key into the ignition, and turn it to ACC mode. The display will illuminate.

When in ACC mode, a green "N" will illuminate at the top of the display; this indicates the 2×2 is in Neutral.

When the key is turned to "RUN", the 2×2 will beep and the "N" light will turn off. Now the 2×2 can be ridden.

Position 1: OFF

Position 2: ACC – 12V power is on. The USB ports, 12V output, display, and horn are now active and your high beam headlight can be turned on.

Position 3: RUN - The 2×2 can now be ridden and the headlight and tail lights are on.

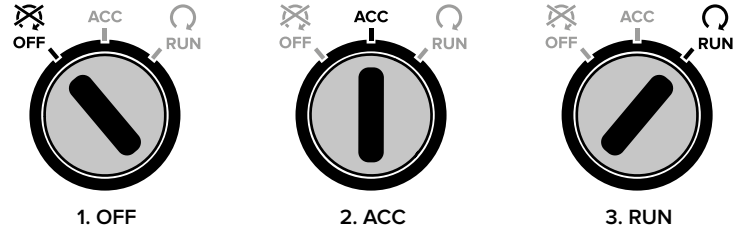

Headlight Control

Due to regulatory requirements, the headlight and tail lights automatically come on when the 2×2 is in "RUN" mode.

To turn off the headlight, the 2×2 must be switched to ACC mode.

The high beam function of the headlight can be activated in ACC mode for when temporary lighting is required while the throttle is inactive.

Handlebar Controls

On the left side of the handlebar you will find a control switch with several different functions. This will be your one stop shop for the lights, indicators, and horn.

A horn is provided to allow you to indicate your presence. Press the red button to sound the horn.

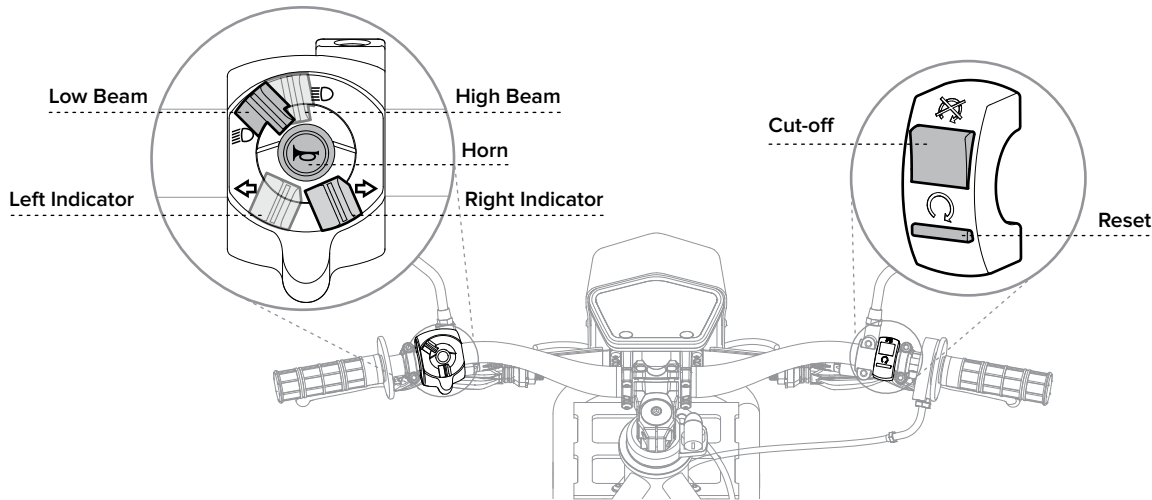

Safety Cut-off

On the right side of the handlebar, next to the throttle, you will find a control with two switches. This is a safety cut-off switch for the motors.

If the switch is off, even if the ignition key is set to “RUN”, the throttle will not be active. To ensure the 2×2 can be ridden, reset this switch and ensure the ignition key is set to “RUN”.

Steering Security Lock

The 2×2 has a steering security lock to lock the steering angle of the 2×2 when parked. This makes the 2×2 very difficult to wheel away as the 2×2 will turn in circles.

The steering lock is located to the right of the steering tube just below the handlebars. The lock is activated with the same key that activates your 2×2's ignition.

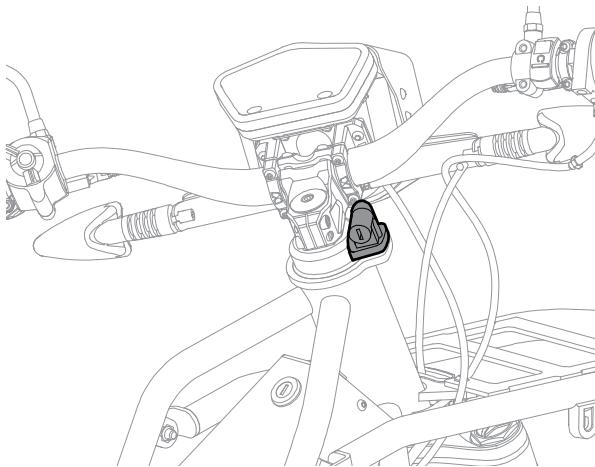

To activate/deactivate the steering lock:

- a. Turn the handlebars to the left until the lock body lines up with the securing ring on the headtube.
- b. With the key engaged, turn the lock barrel clockwise to extend the lock pin into the retaining hole.
- c. Deactivate by turning the key counter clockwise to disengage the lock pin; use the steering as per normal.

It is important to ensure the steering lock is disengaged before starting the 2×2.

Adjusting Your Mirrors

The mirrors on the 2×2 have a pivoting ball joint on the back of the mirror, allowing the mirror to be adjusted to any angle. Hold and tilt the mirror to adjust.

Ensure you have adjusted the mirrors to suit your visibility needs before riding.

Throttle

To accelerate, twist the throttle grip towards you. There are no gears or clutch on the 2×2, so the throttle controls all acceleration from start to maximum speed (excluding gravity).

To maintain a constant speed, you must hold the throttle in a constant position. If you let go of the throttle, it returns to neutral position and the 2×2 is no longer under power.

NOTE: Do not continuously power the throttle when the 2×2 is held stationary, as this can damage the 2×2.

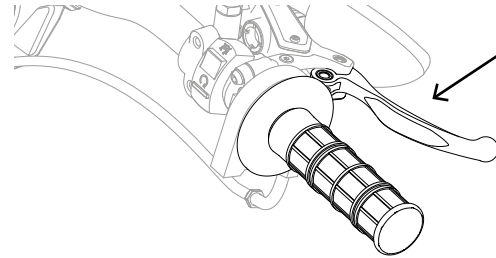
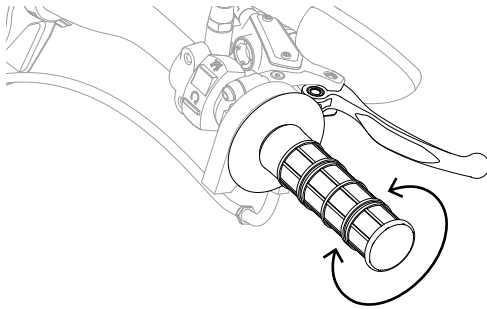

Brake

To brake or slow down, allow the throttle to return to neutral position and apply the brakes via the brake levers on the handlebars: left = rear, right = front.

The 2×2 provides a level of regenerative braking from the drive motors which assist in slowing down the 2×2.

1. The first level of regenerative braking automatically activates when the throttle is returned to its neutral position. This provides a level of braking similar to engine braking on an internal combustion engine 2×2.
2. The second level of regenerative braking activates when the brake lever is pulled. This provides a higher level of braking that assists the 2×2's mechanical brakes.

Your Display

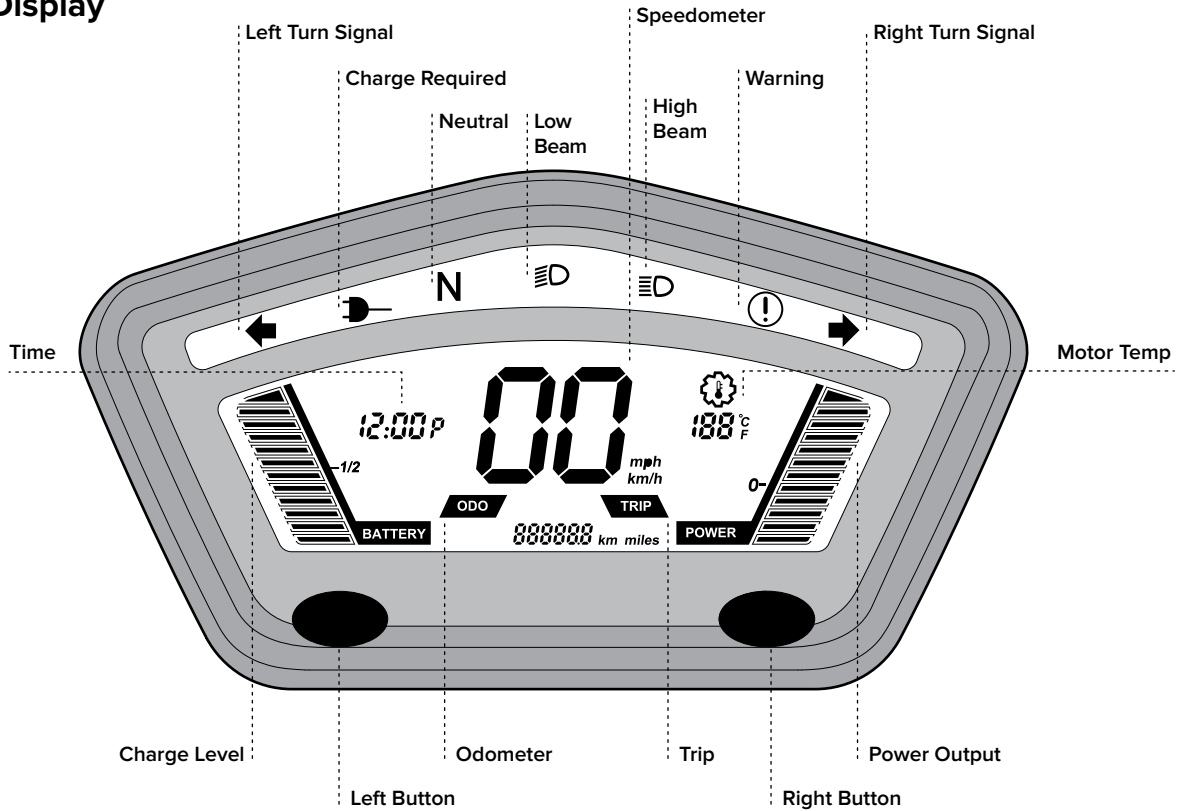

Warning Light

If there is a problem with one of the systems, the warning light on the display will flash and an error code will be displayed in the odometer area on the screen. For information on the error code, including possible causes and solutions, refer to your UBCO 2×2 App.

Reading Your Power pack Level

The power pack display is split up into 12 segments with a halfway indicator between the 6th and 7th segments.

The power pack level is based on power pack voltage. The meter may temporarily drop when the 2×2 is under high load or high acceleration; this is caused by “voltage sag” and does not indicate the level of remaining charge is dropping quickly. The power pack level meter will recover when the load on the motors is reduced.

Changing the Time

Your LCD screen comes equipped with a clock, so you can keep track of the time while you’re out and about. To change the time, follow these steps.

- a. Hold down right button until numbers flash.

- b. Press the right button to change between hours and minutes.
- c. Press or hold down the left button to cycle through numbers.

Odometer and Trip Meter

To select between odometer and trip meter view, press the left button.

To reset the trip meter, press the left button for 7-8 seconds while in the trip view mode.

Switching from Metric to Imperial

To select between metric and imperial units for the speed, odometer and trip meter, while ODO is showing, hold down the left button.

To change between metric and imperial units for the motor temperature, press the right button on the display.

Power Output Meter

The power output meter on the LCD screen displays the real-time power output to the motors.

Any bars shown above the 0 mark represent power output to the motors, and any bars shown under the 0 mark represent power input by the motors through regenerative braking.

Kickstand

The 2×2's kickstand has an auto-retract design so the 2×2 cannot be ridden with the stand down, reducing the risk of the stand catching.

It's important that you keep body parts clear of the stand when removing weight from the stand.

To engage the stand:

- a. Use your foot to rotate the stand down to the ground until it reaches the down stop.
- b. While maintaining the pressure on the stand with your foot, lean the 2×2 over until the weight of the 2×2 is on the stand.
- c. Ensure the weight of the 2×2 is resting on the stand and that the stand is secure.

Retracting the stand:

- a. Simply remove the weight of the 2×2 off the stand and keep body parts clear of the stand – the kickstand spring will cause the stand to retract with force.
- b. Or, use your foot to help guide the stand back to its stowed position.

Adjustable Suspension

Front:

The front forks have adjustable rebound dampening controls that control the rate the suspension re-extends after an impact.

This feature can be adjusted on the top right-hand side of the fork crown. Twist the dial clockwise to slow the rebound; counter-clockwise to speed it up.

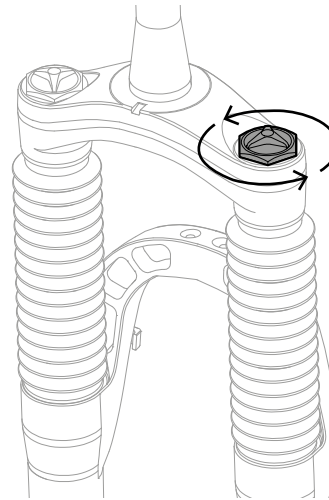

Rear:

The 2×2's rear suspension comes set to an average user setting but can be adjusted.

Wind the disk at the base of the spring clockwise to lessen the spring force and make the suspension softer. Twist counter-clockwise to increase the spring force and make the suspension stiffer.

The rear forks also have adjustable rebound dampening control. It can be adjusted using the red dial at the top of the spring. Twist the dial counter-clockwise to slow the rebound; clockwise speeds it up (this is opposite to the front fork).

The rear suspension and rebound dampening control should be set equally on both sides.

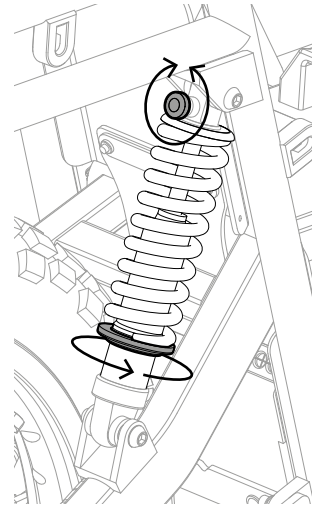

You now have all the information you need to get started! We recommend making yourself familiar with the information in the following sections before you take the 2×2 out for a spin.

We hope you enjoy the 2018 UBCO 2×2, and remember, always ride safe.

03

YOUR POWER PACK

In addition to your 2×2's power supply, your Portage Power System is designed to be a robust, portable power supply accessed through the 2×2. Your power pack (battery) is UN38.3 certified and your charger is UL/CE certified to provide safe operation, use, and transit. The power pack is constructed from high quality Panasonic 18650 Cylindrical Cells, mounted into cell holders, sealed in a fibre-glass enclosure, sealed within an alloy case, and screwed shut.

The power pack is shipped with a nominal charge, so you should fully charge the power pack before the first use.

Removing the Power Pack

The 2×2's power pack is interchangeable, meaning no downtime when working with the 2×2. Extra power packs are available from UBCO Ltd.

- a. Turn off the 2×2 and remove the key.
- b. Unfasten the power pack plug lock with the keyring Torx Tool provided with your 2×2's keys, and unplug from the 2×2. The socket is located on the right-hand side of the power pack.
- c. Remove the power pack strap.
- d. Lift the seat. Lift the power pack out of the 2×2 with two hands.
- e. Store the pack on a stable, cool, dry surface.

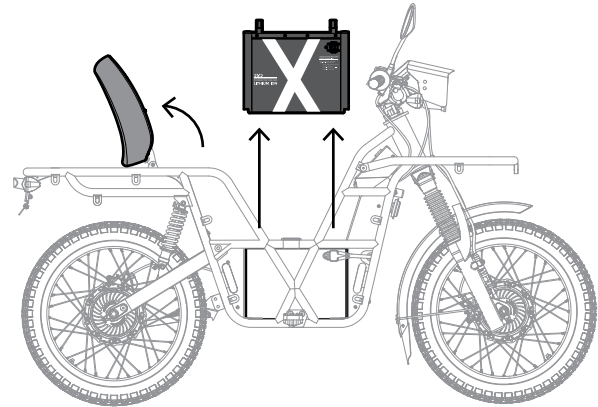
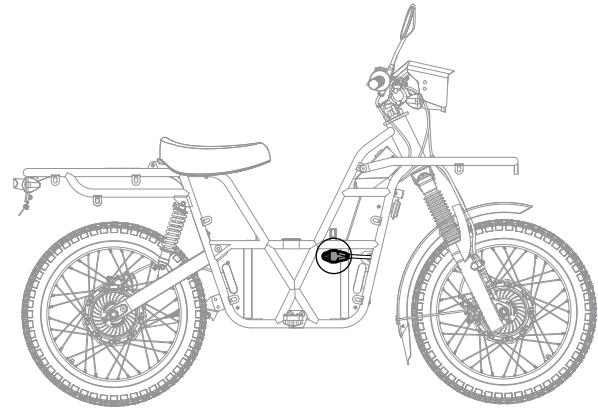
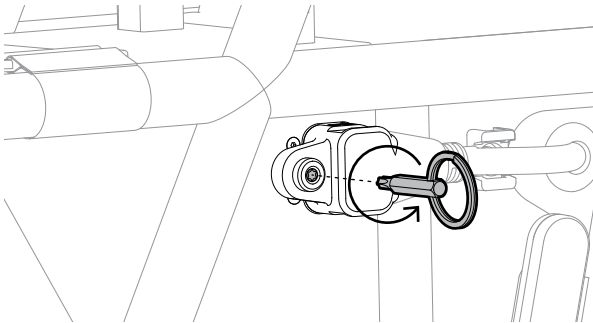

A power socket is located on the right-hand side (when sitting on the 2×2) of the power pack case. Charge ports are located on the front of the power pack and on the right side of the console.

2×2 socket

Connect the power pack to the 2×2 here.

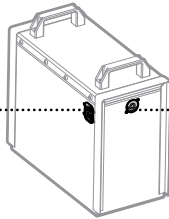

Charge port

Plug in charger here.



TOOL TIP: Attach the power pack strap between the two handles for an easy carrying strap.

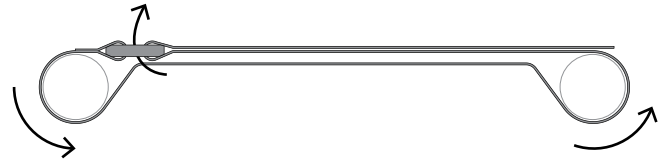
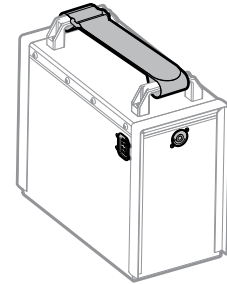

⚠ It's important that the plug, socket, and charge ports stay clean and in good condition to operate properly. If the power pack is removed, ensure that the power pack plug is reinstalled correctly.

⚠ Never store the power pack in an uncharged state. Doing so can void the warranty. Always top up after use.

Charging Your Power Pack

How to charge the power pack:

- a. Turn off the 2×2 and remove the key.
- b. Plug the provided charger into any standard wall socket and switch on at the wall.
- c. Plug the charger into the power port on the console and twist to lock.
- d. The LED indicator lights on the charger will signal:
 - ⊙ **GREEN:** Power pack is full or disconnected
 - ⊙ **RED – Solid:** Charging
 - ⊙ **RED – Flashing:** Charge error

If a charge error occurs, disconnect the charger from the power pack and wall socket. Reconnect. If flashing persists, contact your service provider.

Charger Settings

The charger has two settings: Max and Normal. The recommended setting is Normal.

- **Normal Setting:** Charges the power pack to 90% capacity. This setting is ideal of those not using a full discharge and will extend power pack life.

- **Max Setting:** Charges the power pack to 100% capacity. This setting is useful for high intensity environments and those that require maximum daily range.

When charging:

- ⊙ Keep away from any sparks or flames.
- ⊙ Install a smoke alarm near your charging area.
- ⊙ Do not charge if cables, charger, or power pack are damaged.
- ⊙ Use charger in dry, indoor conditions only and with adequate ventilation.

Checking Power Pack Charge

To check the capacity of your power pack, ensure the power pack is plugged in to the 2×2 and turn the key to ACC or RUN. The power pack meter display on the left hand side of the LCD display will indicate the remaining charge and will flash when the charge gets low.

The yellow 'Charge Required' light at the top of the display will also illuminate when the remaining charge is low.

Charging Powered Devices

When out and about, you can charge your handheld devices and tools via outlets on the console of the 2×2. Be aware that charging your tools and devices will reduce your riding range.

The console on the 2×2 has outlets for you to charge power tools and electronic devices.

Never put foreign objects into the electrical sockets or plugs.

Do not submerge the 2×2 in water and always replace the plug caps when not in use.

Turn the key to ACC or RUN to power the outlets.

The outlets are as follows:

- ① **1x 10A power port** (car style) for charging any 12V device.
- ② **2x USB ports** for charging handheld devices such as mobile phones, tablets, or a GPS.

CAPS ON

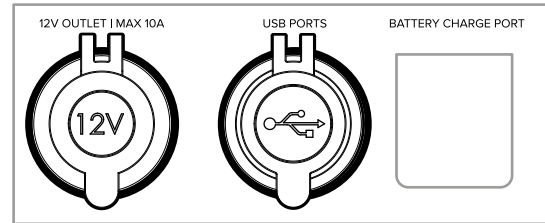

CAPS OFF

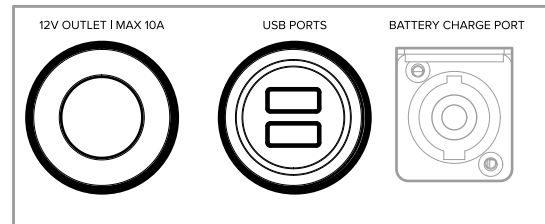

⚠️ Protect the outlets from external elements such as dirt and splashes. When you have finished charging, always replace the rubber caps.

Avoid bumping or knocking the ports when items are plugged in.

Power Pack Care & Safety

The lithium-ion power pack and charger are designed to work exclusively with the 2×2. Do not attempt to use any power pack or charger other than those supplied by UBCO. Extra power packs and chargers can be purchased from UBCO Ltd.

- ⦿ Secure the power pack in place when riding.
- ⦿ Do not drop the power pack into the 2×2 from a height. Lower it into place carefully.
- ⦿ Do not submerge the power pack or the 2×2.
- ⦿ Store in a cool place indoors.
- ⦿ Do not burn the power pack or place it near heat sources above 80°C (176°F).
- ⦿ Keep away from children.
- ⦿ Do not attempt to open the power pack. This will void the warranty. If you have any issues, please contact your service provider.
- ⦿ Charge your power pack overnight at least once a month to ensure the health of the power pack.
- ⦿ Lithium-ion power packs do not suffer from the same charge memory problems as other power packs, therefore they can be topped up at any time.
- ⦿ Always charge your 2×2 indoors and at a temperature between 0-40°C (32°-104°F). Charging the power pack outside of this temperature range could damage your power pack or affect performance and life span.
- ⦿ Lithium is deemed a Class 9 Dangerous Good and so the power pack should always be charged in a non-flammable environment (on a concrete floor, steel shelf, etc.).
- ⦿ If storing for an extended period, ensure the power pack has between 50% and 90% charge. Storing the power pack with either full or too low a charge can cause cell damage, reducing the power pack's life.

04

SAFETY

We want you to have fun riding your 2×2 but take your safety seriously. The 2×2 is a powerful vehicle and should always be operated safely and with caution.

Riding Safety

Due to its electric drive motors, the UBCO 2×2 is silent when on and very quiet in operation. When not in use, be sure to remove the keys from the ignition to prevent accidental activation of the throttle.

When riding the 2×2, regardless of the application, you should always:

- ⊙ Ride the 2×2 within its loading and gradient limits as described in this section.
- ⊙ Follow your local road laws and regulations, both on- and off-road, and ride within your limits.
- ⊙ Be aware of your surroundings, other people, animals, and other vehicles. Drive to the conditions.
- ⊙ Never operate the 2×2 when fatigued, impaired, or under the influence of drugs or alcohol.

Off-road Use

- ⊙ Watch for changes in terrain.
- ⊙ Abide by local off-road riding laws and regulations.
- ⊙ Obtain permission to ride on private property.
- ⊙ Use your horn as a warning signal where it's appropriate.
- ⊙ Do not 'wheely' or jump the 2×2. This can damage the hub motors, causing gear shock when the motor accelerates rapidly in the air and then decelerates instantly when it hits the ground again.

On-road Use

- ⊙ Watch for changes in traffic.
- ⊙ Check your blind spots and signal when turning or changing lanes.
- ⊙ Abide by local riding laws, regulations, and posted speed limits.
- ⊙ Be mindful of other road users; never ride in a way that could cause harm to others.
- ⊙ Use your horn appropriately.
- ⊙ Extra care should be taken when riding in wet, frosty, and/or windy conditions, and when riding over road markings.



Protective Apparel

As with all on- and off-road 2×2s, motorcycles, and mopeds, basic safety apparel should be worn to protect yourself.

You **MUST** always:

- ⊙ Wear a well-fitting helmet securely fastened that provides good all-round visibility.
New Zealand and Australia require you to wear a helmet that meets AS/NZS 1698:2006 for road use. For off-road use under 30km/h you may use a helmet that meets NZS 8600. The US requires you to wear a helmet that is DOT compliant.
- ⊙ Wear adequate protective clothing and sturdy, fully enclosed shoes to protect your feet and ankles.

We also recommend you:

- ⊙ Make yourself easy to see by wearing reflective or high visibility clothing.
- ⊙ Wear gloves to protect yourself from knocks, scrapes, and the elements.
- ⊙ Wear eye protection if your helmet does not provide it to protect yourself from branches, stones, and the elements.

Passengers

We recommend that only one person rides on the 2×2 at any one time. We do not advise that children or inexperienced drivers operate the 2×2.

Lights

As a required safety feature, the front and rear lights turn on automatically when the 2×2 is in “RUN” mode. Ensure the high beam headlight setting is only used when required and not when it could impair oncoming traffic.

Directional Indicators

Always use the directional indicators to signal intended lane changes and turns.



Loading the 2×2

Loading Limits

Improperly loading your 2×2 can affect its stability and handling. Ride with caution when your 2×2 is loaded up.

We recommend you do not exceed 150kg, including your body weight and cargo.

NOTE: This load limit is a suggestion based on testing. We recommend taking the driver's abilities and limitations into consideration when you're loading up the 2×2.

- ⊙ With a load up to 100kg, it is estimated that the maximum gradient is 25%.
- ⊙ With loads exceeding 100kg, max and continuous gradients must be reduced accordingly.

Estimated limits for various gradients are illustrated below. For perspective, Baldwin Street in Dunedin, New Zealand is the world's steepest street at 19° or 35%.

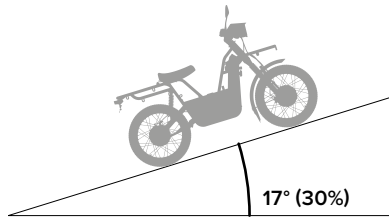

RIDER ONLY

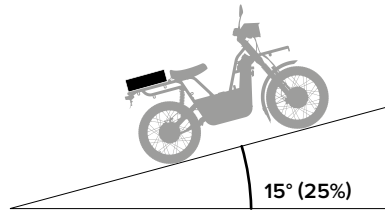

RIDER + CARGO ≤ 100kg

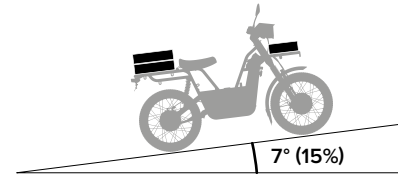

RIDER + CARGO 100-150kg

Loading Safety

- ⊙ Do not put your full weight on the kickstand. They are rated to support the 2×2 and a 50kg load. If load exceeds 50kg, support the 2×2 while loading.
- ⊙ Balance your load evenly.
- ⊙ Do not impede any moving parts on the 2×2.
- ⊙ Do not obscure lights, suspension, steering, or the view from your wing mirrors.
- ⊙ Max load for the front carrier is 20kg.
- ⊙ Max load for the middle of the 2×2 is 50kg.
- ⊙ Max load for the rear carrier is 40kg.

Kickstand Safety

The UBCO 2×2 comes with an auto-retracting kickstand on the left side of the 2×2. This means the kickstand can't be left down when the 2×2 is in use. The kickstand works by relying on the weight of the 2×2 to keep the stand down. If the weight of the 2×2 is lifted off the stand, the stand will spring back to its stowed position.

When removing weight from the kickstand, it is important to keep your legs and other body parts clear of the kickstand's path of movement.

For full instructions on the kickstand see Section 02: Getting Started.

05

ACCESSORIES

Accessory Lugs

The 2×2 is unique in featuring 17 accessory lugs on the frame for attaching tie downs, mounts, and other accessories. This will allow you to adapt the 2×2 to suit your needs. These lugs have been positioned strategically on the frame to provide maximum flexibility.

The accessory lugs use standard M8 bolts. They contain a cavity to house an M8 nut, preventing it from spinning as the bolt is tightened or loosened.

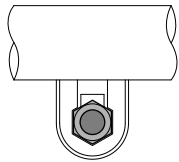

Rear view

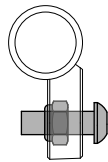

Side view

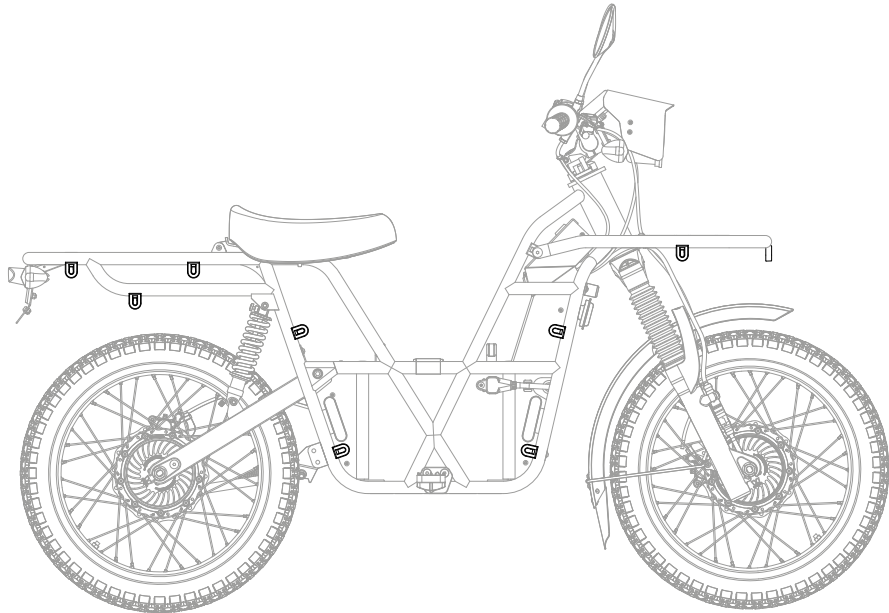

Directional indicators, reflectors, rear light, number plate holder and mirrors on the road version only.

UBCO Accessories

The UBCO 2×2 loves to be kitted out, so we have produced some custom UBCO accessories to help you carry more.

A1 Adapter Pack

Tube Adapters, Velcro Straps, L-Adapters and Fasteners
ACC-AP-001

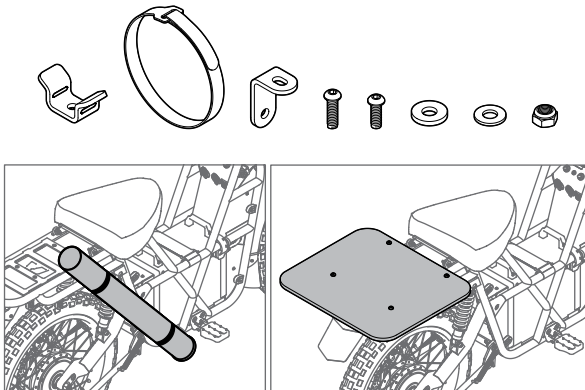

P1 Pannier Frames

ACC-PFS-0-001

P2 Pannier Bag

ACC-PB-0-001

P3 Pannier Backpack

ACC-PBP-0-001

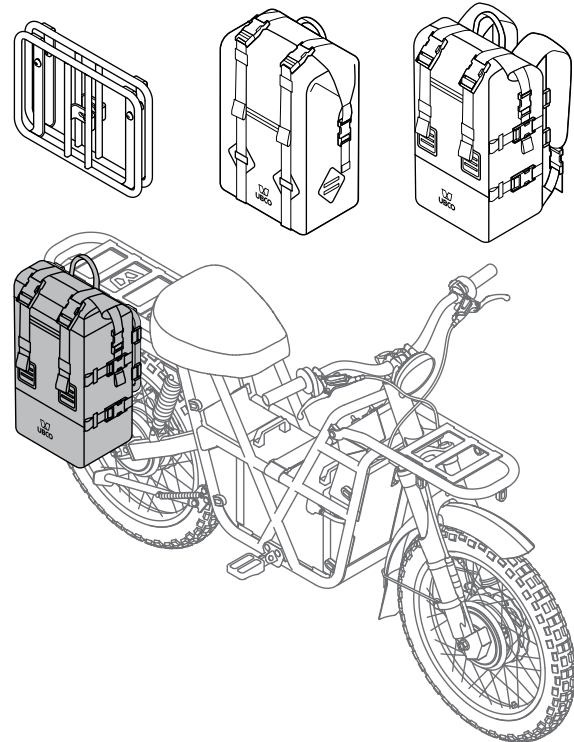



Directional indicators, reflectors, rear light, number plate holder and mirrors on the road version only.

D1 Front Cargo Deck

ACC-FCD-0-001

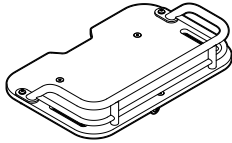

D2 Rear Cargo Deck

ACC-RCD-0-001

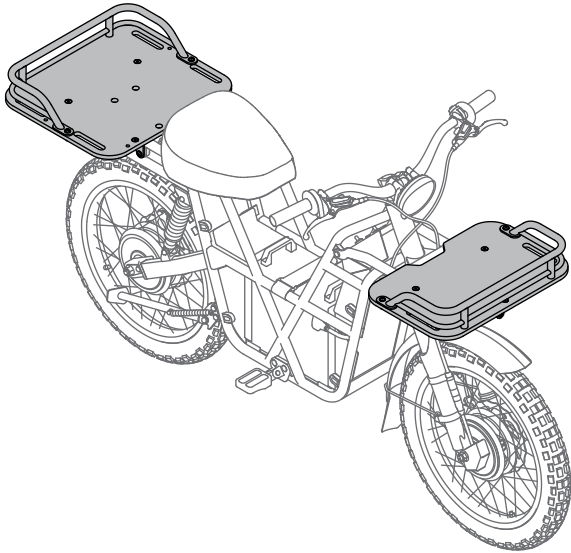
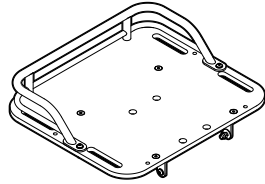

R1 Towball Mount 2x2 Rack

ACC-BR-001

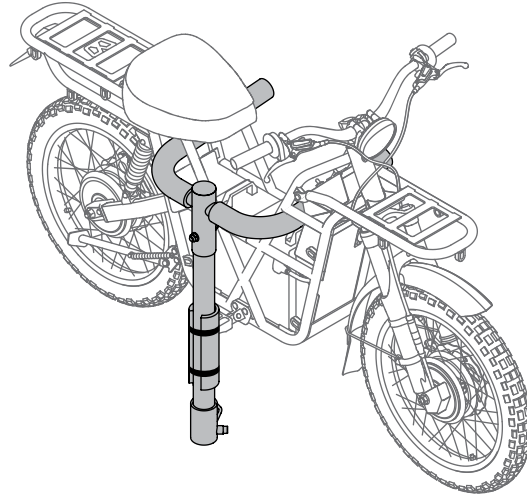
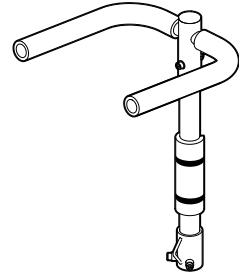



Directional indicators, reflectors, rear light, number plate holder and mirrors on the road version only.

06

**MAINTENANCE
& CARE**

Cleaning

It's important to keep your 2x2 in a good working order so it's ready to go when you are. To ensure it's always in the best condition possible, you should clean your 2x2 after every ride.

Incorrect cleaning methods can void your warranty, so take care and make sure you follow the below points.

Do:

- Clean your 2x2 after each day of use, especially when exposed to dirty terrain or salt water. If you are using the 2x2 in a clean environment, this may not be necessary.
- Before cleaning, turn the 2x2 off and remove the key. Ensure all power outlets, including the power pack, have their rubber seals securely in place. The power pack should be plugged into the 2x2 while cleaning.
- Clean the 2x2 with a low pressure hose and soft automotive cleaning brush or sponge.

Do Not:

- Do not water blast or use a high pressure hose on the 2x2.
- Do not submerge electrical parts – they are protected from the rain and splashes, but should not be left in water.
- Do not use cleaning products that are not specifically designed for cars or motorcycles. They may contain ingredients that could scratch the finish or harm components of the 2x2.

Wheels

The front and rear wheels are identical except for the inserts installed on the axles. This means either wheel can be installed at the front or rear if the correct inserts and torque arms are used.

Removing the Front Wheel:

- Unscrew the motor cable locking sleeves and detach the two motor cable ends.
- With a No. 21 spanner, loosen the two serrated flange nuts. (**TOOL TIP:** It is easiest to remove the nuts from the axle).
- Remove the left and right torque arms from the recesses in the fork, the wheel is now free to be removed from the fork.
- When putting the wheel back on ensure that the nuts are tightened to 80 Nm with a torque wrench.

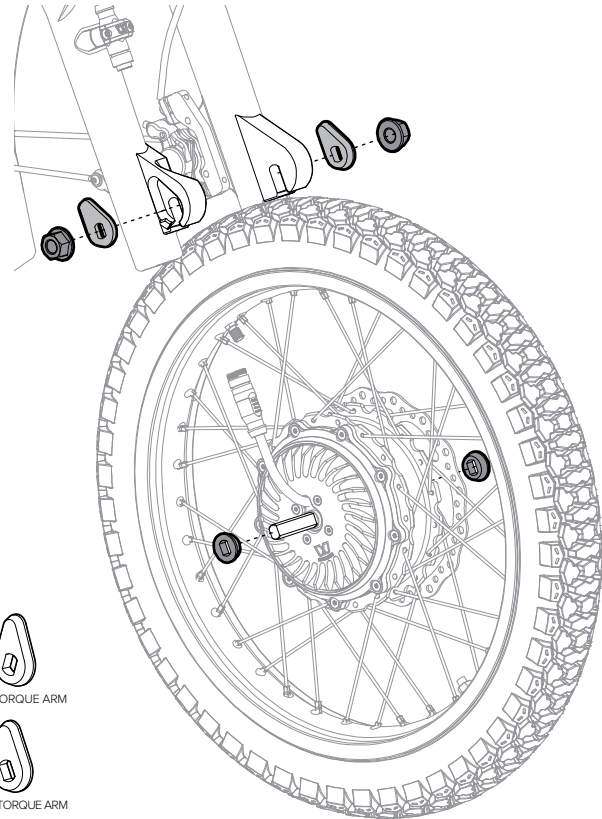

Removing the Rear Wheel:

- Unscrew the motor cable locking sleeves and detach the two motor cable ends.
- Using a 6mm Allen Key unscrew and remove the two M8 countersunk cap screws on the torque arms.
- With a No. 21 spanner, loosen the two serrated flange nuts. (**TOOL TIP:** it is easiest to remove the nuts from the axle).
- Remove the left and right torque arms from the recesses in the swing arm. The wheel is now free to be removed.
- When putting the wheel back on ensure that the nuts are tightened to 80 Nm with a torque wrench.

Swapping Front and Rear Wheels

The front and rear wheels each have spacer inserts which are installed on the axles. These inserts are specific for installation in the front fork and rear swing arm. If you wish to swap the wheels around for whatever reason, be sure to swap these inserts and torque arms before installing into the 2×2.

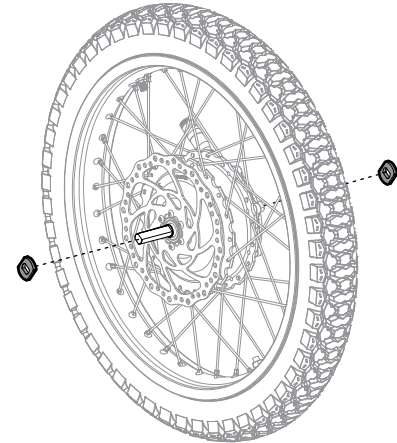
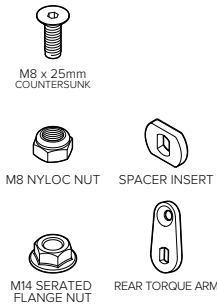
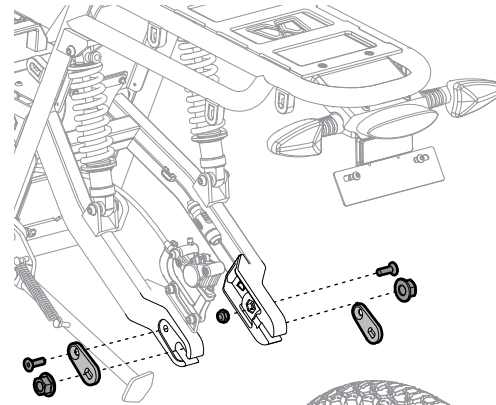

Removing Front Mud Guard

Removing the front mud guard can be completed in a few easy steps. It is easier to remove the mud guard if the front wheel is removed.

- a. Using a 3mm Allen key, remove the two side bolts connecting the wire mud guard stay to the fork near the brake calliper.
- b. Using a 3mm Allen key and 8mm spanner, remove the two bolts that hold the mud guard to the fork arch.
- c. Remove the mud guard.

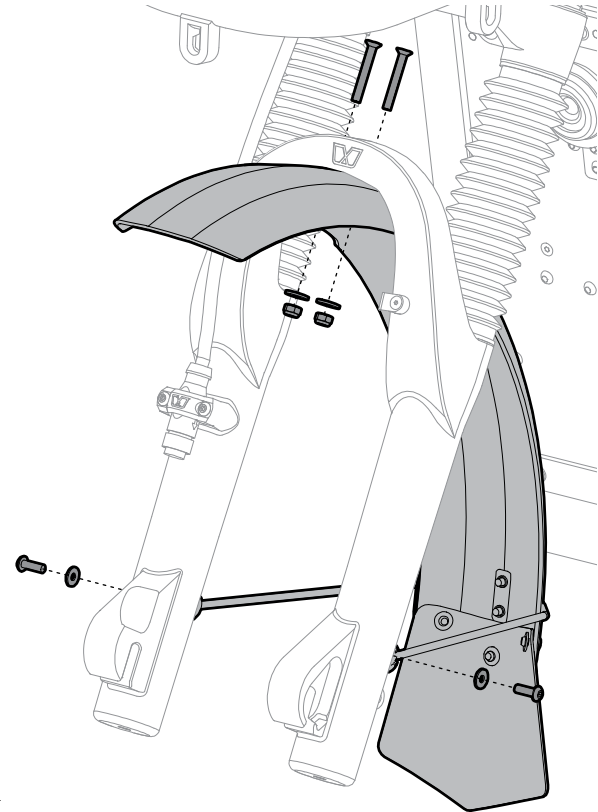

M5 x 40mm
COUNTERSUNK

M5 X 12.5mm
WASHER

M5 x 16mm

M5 NYLOC NUT

Replacing Brake Pads

The 2×2 includes front and rear hydraulic disk brakes, operated by levers on the handlebars.

Ensuring your brake pads are in good condition is critical to your safety. Check the brake pads regularly, especially when a lot of heavy braking has occurred.

Replacement brake pads are Tektro D40.11 and are available from UBCO Ltd.

⚠ Brake rotors get hot during braking. Allow sufficient time for brakes to cool before touching or doing any maintenance.

To replace the brake pads:

- a. Unscrew the pin on the top of the calliper body with a number 3 Allen key, remove the end clip and pull the pin out.
- b. Remove the brake pads from the top of the calliper and discard. Guide new brake pads in, from the top of the calliper, until the holes line up. Do not touch the pad surface with your skin.
- c. Re-install the fastening pin and tighten with the Allen key. Replace the end clip.

a.

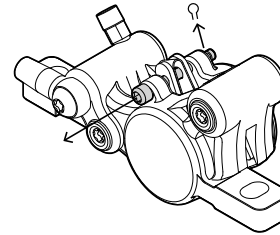

b.

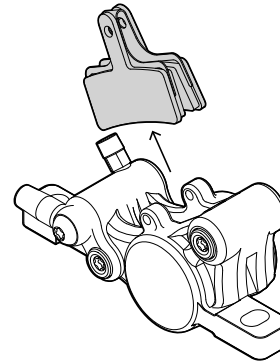

c.

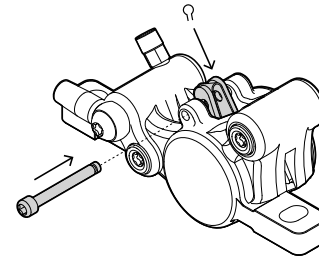

07

COMPLIANCE

Vehicle Compliance

The UBCO 2×2 is available in two models: a dual-use model and an off-road model. The off-road model cannot be registered for on-road use. The dual-use model is a type rated vehicle that complies with the following country vehicle regulations:

- ⦿ **Australia:** LA Class (Moped). This vehicle was manufactured to comply with the Australian Motor Vehicle Safety Standards Act 1989.
- ⦿ **New Zealand:** LA Class (Moped). This vehicle was manufactured to comply with the Australian Motor Vehicle Safety Standards Act 1989, which is accepted in New Zealand.
- ⦿ **United States:** This vehicle conforms to all applicable Federal Motor Vehicle Safety Standards (FMVSS) in effect on the date of manufacture. This is classified as a 'Motorcycle' with a 'Motor Driven Cycle' exception being under 5 BHP and having a maximum obtainable speed of 30mph.

FCC Compliance

This equipment has been tested and found to comply with the limits for a Class B digital device,

pursuant to part 15 of the FCC Rules. These limits are designed to provide reasonable protection against harmful interference in a residential installation. This equipment generates, uses and can radiate radio frequency energy and if not installed and used in accordance with the instructions, may cause harmful interference to radio communications. However, there is no guarantee that interference will not occur in a particular installation. If this equipment does cause harmful interference to radio or television reception, which can be determined by turning the equipment off and on, the user is encouraged to try to correct the interference by one or more of the following measures:

- ⦿ Reorient or relocate the receiving antenna.
- ⦿ Increase the separation between the equipment and receiver.
- ⦿ Connect the equipment into an outlet on a circuit different from that to which the receiver is connected.
- ⦿ Consult the dealer or an experienced radio/TV technician for help.

